



DESIGN
for
CONSTRUCTION



EUREKA PROJECT 130

CIM steel

CIMsteel

The Eureka project EU130 "CIMsteel" is a visionary, Europe-wide collaboration. It will place the European constructional steelwork sector in a leading position to compete with both overseas steel construction industries and alternative construction materials.

Improved integration will be achieved by developing methods for "Computer Integrated Manufacturing for Constructional Steelwork". These will streamline the process of integrating the life-cycle of structural steelwork projects, encompassing design, analysis, detailing, fabrication and erection.

The CIMsteel Vision is:

- Faster design, manufacture and construction
- Improved, cheaper steelwork structures
- Unlocking potential for growth in the steelwork market
- Improved competitiveness in the world market

The CIMsteel project will turn an insular craft industry, made up of many small and medium sized companies into a state-of-the-art integrated manufacturing industry.

More than forty two organisations from eight European countries are collaborating to research and develop advanced but easy to use standards, methods and software to improve the effectiveness and competitiveness of the steelwork sector of the construction industry.

European countries taking part in this venture include:

Austria	Sweden
Denmark	Italy
Finland	The Netherlands
France	United Kingdom

This phase of the CIMsteel project in the United Kingdom has fourteen collaborating organisations and *receives support from the Department of Trade and Industry*. Taylor Woodrow Construction Holdings Ltd is the lead organisation. The Steel Construction Institute is the publisher for the CIMsteel documents.

SCI PUBLICATION 178

Design for Construction

Published by:

**The Steel Construction Institute
Silwood Park, Ascot
Berkshire SL5 7QN**

**Telephone: 01344 23345
Fax: 01344 22944**

© 1997 The Steel Construction Institute

Apart from any fair dealing for the purposes of research or private study or criticism or review, as permitted under the Copyright Designs and Patents Act, 1988, this publication may not be reproduced, stored, or transmitted, in any form or by any means, without the prior permission in writing of the publishers, or in the case of reprographic reproduction only in accordance with the terms of the licences issued by the UK Copyright Licensing Agency, or in accordance with the terms of licences issued by the appropriate Reproduction Rights Organisation outside the UK.

Enquiries concerning reproduction outside the terms stated here should be sent to the publishers, The Steel Construction Institute, at the address given on the title page.

Although care has been taken to ensure, to the best of our knowledge, that all data and information contained herein are accurate to the extent that they relate to either matters of fact or accepted practice or matters of opinion at the time of publication, The Steel Construction Institute, the authors and the reviewers assume no responsibility for any errors in or misinterpretations of such data and/or information or any loss or damage arising from or related to their use.

Publications supplied to the Members of the Institute at a discount are not for resale by them.

Publication Number: SCI-P-178

ISBN 1 85942048 6

British Library Cataloguing-in-Publication Data.

A catalogue record for this book is available from the British Library.

FOREWORD

This guide, produced as part of the Eureka CIMsteel project, is a companion document to the *Design for Manufacture Guidelines* produced under phase 1 of the project. It was written by a collaborative group which included fabricators, consulting engineers, research organisations and academics.

The general aim of the document is to raise awareness of the effects that basic design decisions can have on the overall buildability and cost of a building. The right decisions can help to reduce conflict in the design and construction process, and reduce the likelihood of expensive remedial work.

The document is primarily intended for use by practising engineers and engineering students, but also has relevance to quantity surveyors, architects, estimators and fabricators, i.e. the various parties associated with steel construction. Its scope is therefore limited to the steel frame itself, and those components which interface directly with the frame. Furthermore, its focus is modern commercial and industrial buildings.

Principal authors (*) and other collaborators involved in this project were:

David Brown*	The Steel Construction Institute
Dr Graham Couchman*	The Steel Construction Institute
Kim Dando	Glosford MCL Ltd
Charles Fowler	The University of Reading
Colin Gray	The University of Reading
Alistair Hughes	Ove Arup & Partners
John Knott	Glosford MCL Ltd
Prof David Nethercot	The University of Nottingham
Dr Roger Pope*	The Steel Construction Institute
Peter Purvey*	Taylor Woodrow Construction
Philip Quantrill	Philip Quantrill (Structural Engineers) Ltd
Ron Swift	Severfield Reeve Structures Ltd

Valuable comment was also received from the following reviewers:

Ian Benson	Nusteel Structures Ltd
Geoff Buckton	Waterman BBT
David Cunliffe	Rowen Structures Ltd
David Curtis	Laing Technology Group Ltd
Dr Buick Davison	The University of Sheffield
Martin Double	W S Atkins Ltd
Vic French	Ayrshire Metal Products plc
Victor Girardier	SCIF
Bob Gordon	MACE
Ian Grace	Building Design Partnership
Bob Lark	Cardiff School of Engineering, The University of Wales
Steve Mason	Billington Structures Ltd
Alan Pottage	Ward Building Components Ltd
John Rushton	Peter Brett Associates
Peter Swindells	Caunton Engineering Ltd
Alan Todd	British Steel (Sections, Plates & Commercial Steels)
Nigel Waddington	Fluor Daniel Ltd

CONTENTS

	Page No.
FOREWORD	iii
SUMMARY	vii
1 INTRODUCTION	1
2 PLANNING FOR CONSTRUCTION	3
2.1 The need to plan for construction	3
2.2 General principles	3
2.3 Management of the design process	5
2.4 Further reading	10
3 DESIGNING FOR CONSTRUCTION	13
3.1 Design principles	13
3.2 Frame types	14
3.3 Floor systems	16
3.4 Connections	19
3.5 Bolts	26
3.6 Welding and inspection	27
3.7 Corrosion protection	27
3.8 Interfaces	27
3.9 Further reading	28
4 SITE PRACTICE	31
4.1 General features of site practice	31
4.2 Erection equipment and techniques	40
4.3 Case study - Senator House	47
4.4 Further reading	50
5 HEALTH AND SAFETY - THE CDM REGULATIONS	53
5.1 The Regulations	53
5.2 Duties under CDM	53
5.3 Designer's responsibilities	54
5.4 Designer's response	56
5.5 Further reading	59
6 INTERFACES WITH STRUCTURAL COMPONENTS	61
6.1 Foundations	61
6.2 Concrete and masonry elements	65
6.3 Timber elements	69

6.4	Composite beams	70
6.5	Precast concrete floors	77
6.6	Crane girders and rails	79
6.7	Cold formed sections	83
6.8	Further reading	86
7	INTERFACES WITH NON-STRUCTURAL COMPONENTS	89
7.1	Services	89
7.2	Lift installation	90
7.3	Metal cladding	92
7.4	Curtain walling	96
7.5	Glazing	97
7.6	Brickwork restraints	99
7.7	Surface protection	101
7.8	Further reading	105
8	TOLERANCES	109
8.1	Reasons for tolerances	109
8.2	Inspection and test plan	110
8.3	Further reading	111
9	REFERENCES	113
10	CODES AND STANDARDS	121
APPENDIX A	- Additional information	125
A.1	Introduction	125
A.2	Typical tonnages for various types of building	125
A.3	Case study references	126
A.4	Potential defects	130

SUMMARY

Basic design decisions can have a considerable effect on the overall buildability and cost of a building. The right choices can help to reduce conflict in the design and construction process, and to reduce the likelihood of expensive remedial work. Focusing on modern commercial and industrial buildings, this publication provides advice to help the designer make the right choices.

Before commencing a design, it is essential that due attention is paid to planning. The first part of the publication therefore deals with planning and management issues.

Guidance on the issues to be considered when designing for construction are described, to help the designer choose an appropriate frame layout, and to make decisions concerning more detailed aspects of the frame. This guidance is supported by more extensive information given later in the publication.

In order to make the right design choices, the designer needs an understanding of the construction process. An overview of site practice is therefore included. Details are given of the equipment and techniques which may be used. Specific attention is paid to health and safety issues.

One of the keys to producing an 'efficient' frame design is to pay particular attention to interfaces with other building components. In order to reduce the overall building cost, conflict must be avoided. Extensive guidance on issues to be addressed at interfaces, such as different tolerance requirements, is given.

Finally, a summary of published case studies that provide a portfolio of photographs and descriptions of actual projects is given in an appendix. This appendix includes typical weights for various building forms, and a list of 'common' defects.

Concevoir pour construire

Résumé

Les premières options prises lors de la conception peuvent avoir un effet considérable sur la réalisation et le coût d'une construction. Les bons choix peuvent aider à réduire les conflits entre le processus de conception et le processus de réalisation et réduire les modifications ou changements en cours de construction, qui se révèlent souvent très coûteux. Consacrée essentiellement aux immeubles modernes destinés à des fins industrielles ou commerciales, cette publication est destinée à aider le concepteur à réaliser les bons choix.

Avant d'aborder la conception, il est essentiel de porter attention au planning. La première partie de la publication est consacrée à ce point ainsi qu'au management du projet.

On donne ensuite un certain nombre d'informations permettant au concepteur de choisir les bonnes dispositions et géométries de la structure. Cette partie a pour l'appui des informations approfondies dans la suite de la publication.

Pour effectuer les bons choix, le concepteur doit connaître et comprendre le processus de construction. Un survol de la pratique de chantier est donné dans la publication. Les équipements et techniques utilisables sont passés en revue. Une attention particulière est apportée aux problèmes de sécurité et de santé.

Une des clés pour obtenir une structure efficace est, sans conteste, d'apporter une grande attention aux interfaces entre la structure et les autres composants de la construction. Ceci permet d'éviter des problèmes délicats à résoudre, et ainsi de réduire le coût total d'une construction. Les tolérances de réalisation sont également reprises dans la publication.

Enfin, un résumé de cas pratiques, constituant un portefeuille de photos et de descriptions de projets fait l'objet d'une annexe qui inclut des exemples de poids pour différentes formes structurales ainsi qu'une liste des principaux défauts observés en pratique.

Entwurf von Bauwerken

Zusammenfassung

Grundlegende Entscheidungen beim Entwurf können eine beachtliche Wirkung auf Baubarkeit und Kosten eines Gebäudes haben. Die richtigen Entscheidungen können dazu beitragen, Konflikte bei der Planung und in der Bauphase sowie die Wahrscheinlichkeit für teure Nachbesserungen zu reduzieren. Vor dem Hintergrund moderner Geschäfts- und Industriebauten gibt diese Publikation dem Planer Ratschläge, die ihm helfen, die richtigen Entscheidungen zu treffen.

Vor dem Entwurf ist es absolut notwendig, der Planung die ganze Aufmerksamkeit zu widmen. Der erste Teil dieser Veröffentlichung beschäftigt sich daher mit Planungs- und Managementfragen.

Es werden Anleitungen gegeben für Fragen die beim Entwurf Berücksichtigung finden, damit der Planer ein passendes Tragwerk wählen und Entscheidungen bezüglich genauerer Aspekte des Tragwerks treffen kann. Diese Anleitungen werden mittels genauerer Informationen weiter hinten in der Veröffentlichung ausführlicher behandelt.

Um beim Entwurf die richtigen Entscheidungen zu treffen, muss der Planer den Bauprozess verstehen. Daher ist ein Überblick zur Baustellenpraxis enthalten. Einzelheiten zu Ausstattung und Techniken werden angegeben. Besondere Aufmerksamkeit wurde Gesundheits- und Sicherheitsfragen gewidmet.

Ein Schlüssel für ein wirtschaftliches Tragwerk liegt in der besonderen Berücksichtigung nachfolgender Gewerke. Um die gesamten Baukosten zu reduzieren, müssen Konflikte vermieden werden. Ausführliche Anleitung zu Problemen nachfolgender Gewerke, z.B. verschiedener Toleranzen, sind enthalten.

Eine Zusammenfassung veröffentlichter Fallstudien aktueller Projekte ist im Anhang zu finden. Dieser Anhang schließt Gewichtsangaben für verschiedene Gebäudeformen und häufige Mängel mit ein.

El proyecto en la construcción

Resumen

Las decisiones fundamentales durante la fase de proyecto pueden tener un efecto considerable tanto en el coste total como en la edificabilidad de una construcción. Una correcta decisión puede ayudar a reducir los conflictos entre las etapas de proyecto y construcción y reducir la posibilidad de tener que realizar unos caros trabajos correctivos. Centrándose en las construcciones modernas, tanto comerciales como industriales, esta publicación proporciona consejos para ayudar al proyectista a tomar las decisiones apropiadas.

Antes de comenzar con el proyecto, es fundamental prestar la debida atención a la fase de planificación. Es por esto, por lo que la primera parte de la publicación contempla temas de planificación y de organización.

Además, se muestra una guía de los aspectos a considerar durante la fase de proyecto en la construcción, tanto para ayudar al proyectista a elegir una apropiada tipología estructural como para tomar decisiones relativas a aspectos más detallados de dicha tipología. Esta guía se apoya en la amplia información que se aporta a lo largo de toda la publicación.

Para tomar las decisiones correctas de proyecto, es necesario que el proyectista conozca el proceso de construcción, para lo que se incluye una visión general de los procedimientos a pie de obra y algunos detalles de los equipos y técnicas que pueden emplearse, prestando especial atención a los aspectos de seguridad e higiene.

Una de las claves para producir un proyecto eficaz de la estructura es prestar especial atención a las relaciones con otros elementos de la construcción, ya que evitando estos conflictos es posible reducir los costes totales de la edificación. Así, se suministra una guía completa sobre los aspectos a considerar, en cuanto a dichas interrelaciones, como pueden ser los diferentes requisitos de tolerancias.

Por último, en uno de los apéndices se muestra un resumen de varios ejemplos de estudio publicados con una colección de fotografías y con descripciones de proyectos actuales. Este apéndice incluye pesos típicos para diversas formas de edificios y una lista de los defectos más comunes.

Progetto di costruzioni

Sommario

Le scelte fondamentali della progettazione devono tenere in conto l'abitabilità globale della struttura e i costi dell'edificio. In aggiunta, decisioni corrette possono certamente essere di aiuto nel ridurre sia il conflitto tra la progettazione e il processo costruttivo sia la probabilità di ulteriori costi relativi a lavori non previsti. Fissando l'attenzione sui moderni edifici ad uso commerciale e industriale, questa pubblicazione fornisce informazioni di aiuto al progettista per operare scelte convenienti.

A monte della fase progettuale appare in primo luogo necessario prestare la dovuta attenzione alla pianificazione. La prima parte di questa pubblicazione tratta di conseguenza tematiche relative a pianificazione e organizzazione.

La guida sugli argomenti da tenere in conto nella fase di progettazione strutturale è di concreto aiuto al progettista per scegliere un appropriato schema dell'ossatura portante e per definire anche i relativi dettagli. Tale guida è comunque supportata da informazioni particolareggiate, fornite in una successiva parte della pubblicazione.

Al fine di effettuare le corrette scelte progettuali è al progettista necessario comprendere a fondo il processo costruttivo. Al riguardo, viene trattato in modo generale l'argomento della pratica di cantiere e sono fornite informazioni sulle attrezzature e sulle tecniche maggiormente utilizzate. Specifica attenzione viene prestata alla salubrità dell'ambiente di lavoro e alla sicurezza.

Uno degli aspetti chiave per lo sviluppo di un efficace progetto strutturale consiste nel prestare particolare attenzione alle interfacce con le altre componenti dell'edificio. Al fine di ridurre i costi globali della costruzione, interazioni negative devono essere evitate. Una dettagliata guida su argomenti relativi alle interfacce, così come alle differenti richieste di tolleranze, è quindi contenuta nella pubblicazione.

Un riassunto relativo a casi significativi già realizzati, corredato da informazioni fotografiche e descrittive, è infine fornito in appendice. Questa include anche i pesi delle varie tipologie strutturali considerate ed elenca i principali difetti ad esse associati.

Konstruera för att bygga

Sammanfattning

Tidiga beslut i utformningen av byggnaden kan få avsevärd effekt på möjligheten att genomföra projektet till en rimlig kostnad. Rätt beslut kan eliminera risken för konflikter mellan utformning och produktion samt reducera risken för kostsamma ändringsarbeten. Med fokus på moderna kommersiella byggnader och industribyggnader ger denna publikation vägledning för konstruktören att fatta de rätta besluten.

Innan utformningen av byggnaden påbörjas är det nödvändigt att lägga stor möda på planering av projektet. Den första delen av publikationen behandlar därför planering och managementfrågor.

Vägledning ges till de punkter som bör tas i beaktande vid ett konstruktionsarbete som underlättar byggprocessen. Vägledning ges för en lämplig layout och detaljutformning av stommen. Denna vägledning kompletteras med mer omfattande information längre fram i publikationen.

För att fatta de rätta besluten behöver konstruktören ha god kännedom om byggprocessen. Därför finns en översiktlig beskrivning av den praxis som råder på byggarbetsplatsen samt den utrustning som kan komma att användas vid uppförandet av byggnaden. Speciell uppmärksamhet riktas mot arbetsmiljö och säkerhetsfrågor.

En av nycklarna till en "effektiv" stommutformning är att lägga speciell uppmärksamhet vid samordning med stommkompletteringen. För att reducera totalkostnaden för byggnaden är det nödvändigt att undvika konflikter här. Speciell vägledning ges till denna samordning, t ex vilka toleranser man bör ha.

Slutligen presenteras ett antal referensobjekt med fotografier och beskrivningar i ett appendix. Här återfinns även totalvikten för byggnader med olika form samt "vanliga" misstag.

1 INTRODUCTION

There is a common misconception that the lowest cost solution for a steel-framed building will be the structure containing the least tonnage of steel. However, in the current climate of relative material and labour costs this is not normally true. Minimum weight usually equates to complexity, involving extensive local stiffening, and stiffeners have a large influence on the cost of fabrication and erection. As a rule-of-thumb, for every fabrication hour saved, 100 kg of steel could be added to the frame without any cost increase (based on average 1996 UK prices).

Complexity also lengthens fabrication and erection periods. Longer construction periods may delay the return on a client's investment. Design decisions which affect construction time are just as important as those directly related to material costs.

In a design and build situation, the steelwork contractor may well take advantage of the commercial benefits of rationalising and simplifying the steel frame. However, in the more common fabricate and construct contract, critical decisions on the basic form of the steel frame often need to be taken before the steelwork contractor is involved. Programme constraints usually preclude the possibility of introducing design changes after awarding the steelwork contract, so the designer should take account of construction aspects from the outset.

The principal designer is in the strongest position to influence the project, firstly because he is involved from a very early stage, and secondly because he has a global overview. He must, as far as is possible, take account of the implications for construction of aspects such as the building services, even though these are not directly related to the building frame for which he is responsible.

This publication presents an overview of the information that a designer requires in order to produce a 'buildable' design, to the overall benefit of the project. At the end of each Section, **Further Reading** lists provide the reader with details of potential sources of further information on particular topics. References are listed formally in Section 9.

A formal list of relevant codes and standards, some of which are referred to in the text, is given in Section 10.

Two types of "boxes" appear throughout the publication. The shaded "Actions" boxes highlight the principal actions on the designer, and the "Key Points" boxes summarise the points on a given subject.

Produced as a part of the Eureka CIMsteel project, this guide is a companion document to the *Design for manufacture guidelines*⁽¹⁾ produced under phase 1 of the project.

2 PLANNING FOR CONSTRUCTION

2.1 The need to plan for construction

There is often a great temptation to jump immediately into the detailed design of a project. Little time is spent on planning the design, in the belief that this will improve productivity. However, time spent on planning can nearly always be justified; shorter programmes, reduced uncertainty and overall cost savings can be achieved.

In planning the design to best satisfy the client's needs in terms of the building required, its cost, and the available timescale, it is essential to consider construction. By doing so it will be possible to produce a design that facilitates construction. Such an approach is sometimes called *construction led* design. The following aspects of the project are affected by this approach:

- basic design decisions (without violating other constraints)
- flow of information at the design and construction stages
- sequencing of work both on and off-site.

It should be noted that the consideration by the designer of how his design could be put into practice is also a requirement of the CDM regulations⁽²⁾, since such consideration facilitates safe construction (see Section 5).

2.2 General principles

When planning for construction, a designer should follow the five principles given below:

- carry out a thorough investigation
- plan for essential site production requirements
- plan for a practical sequence
- plan for simplicity of assembly
- plan for logical trade sequences.

These principles are taken from CIRIA guide SP26⁽³⁾, selecting those specifically relating to planning from a general list. Their relevance to the design of steelwork is highlighted in the Sections that follow.

2.2.1 Thorough investigation

A thorough and complete investigation of the site is needed before commencement of design, and the information obtained must be clearly presented. This is an essential starting point for avoiding costly modifications at a later date. The investigation should provide the designer with information concerning the following:

- ground conditions
- ground levels
- access to and throughout the site
- particulars of adjacent structures affecting or affected by the works

- special environmental conditions
- details of underground services, overhead cables and site obstructions
- provision of hard standing for cranes and access equipment, as this may influence the plant that can be used for erection.

2.2.2 Site production requirements

The layout of a building or buildings on site should wherever possible recognise the requirements of site access, material handling and construction sequences. Access to and around the site may impose limitations on the size of members that can be used. These limitations may, in some cases, dictate the whole philosophy of the frame design. For example, a design which utilises a truss to give a large, clear span, is inappropriate if the truss is too large to be assembled on site and then erected.

In addition to physical constraints, the design philosophy may be dictated by time constraints on site. A 'construction led' approach means that the construction programme has a major influence on design decisions. For example, a restrictive construction programme may necessitate the incorporation of pre-fabricated components in the design. Pre-fabrication may also be appropriate for export work when labour costs on site are high, or there is a shortage of skilled labour.

2.2.3 Practical sequence

The designer will need to determine a possible construction sequence that would satisfy the requirements of a main contractor, whilst maintaining stability of the structure at all stages of construction. Computer modelling may be useful in developing the erection sequence, using a 'virtual prototype' (see Figure 2.1). The sequence should optimise plant use when practical; plant should not be idle for long periods of time, and principal member weights should not vary widely, so that craneage can be used efficiently.

The form of construction should be one that encourages the most effective, and safe, sequence of building operations. The designer should outline the assumptions made when developing the design in a 'design basis method of erection' (DBME), to use terminology from ENV 1090-1. The DBME should be included in the Health and Safety Plan (see Section 5). It is worth emphasizing that the DBME outlines the possible method of erection which the designer assumed, but it does not prohibit the adoption of an alternative method by the contractor.

Although additional method statements must normally be produced for each significant site operation, this is not the responsibility of the designer. They will be produced by the contractor, and should be compatible with the Health and Safety Plan. In this way, potential problems and safety issues, such as working near overhead cables or over water, are thought through in advance. The contractor will send these method statements to the client's representative for approval.

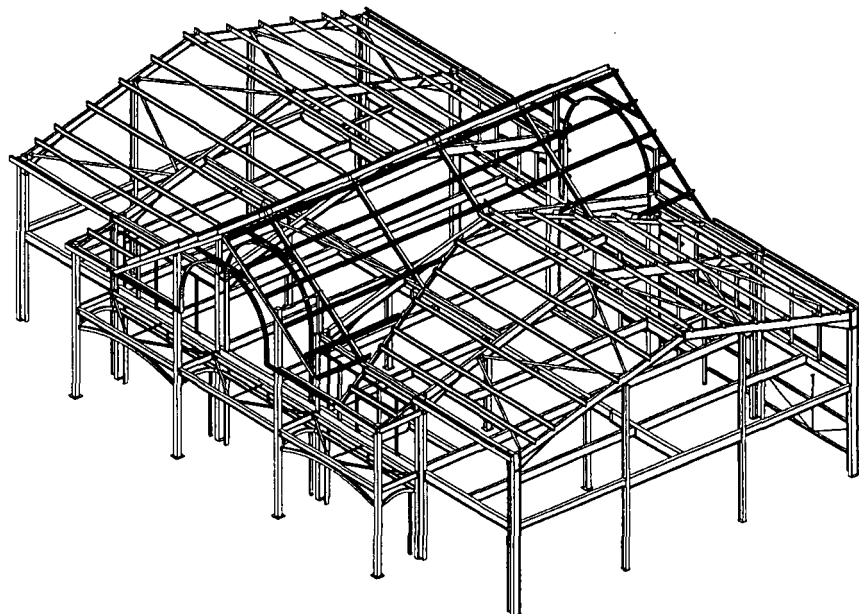

Figure 2.1 *Computer model, produced using CSC Xsteel software, of a steel frame (courtesy of Barrett Steel Buildings Ltd)*

2.2.4 Simplicity of assembly

The designer should design and detail a building to encourage simplicity of assembly. Standard, simplified connections should be used wherever possible. Time and cost penalties are often associated with less familiar forms of construction (see Section 3.3), because of the ‘learning curve’ effect. Repetitious, automated procedures, and the use of trial assemblies for complex parts of a structure can all help to speed construction and reduce costs.

2.2.5 Logical trade sequences

The main contractor will establish a master contract programme based on logical trade sequences and availability of information. This programme will be arranged to minimise the need for return visits, and optimise the time spent on site. The designer’s choices can have a substantial influence on the potential ‘efficiency’ of this programme. For example, the use of steel decking in a multi-storey frame enables following trades to work at lower levels as steelwork erection continues up the building (see Section 6.4). The programme for steelwork erection will be more detailed than the master programme, but clearly must be compatible with it.

2.3 Management of the design process

A publication produced by the Institution of Structural Engineers, *Communication of structural design*⁽⁴⁾, lists several stages in the development of a project. The schedules given in that publication form a suggested framework containing the sequence of operations in which designers may be involved on any project, from inception to completion of the work. A consulting engineer would typically be involved in the design process from the feasibility study, and carry on through subsequent stages of design development to the preparation of production information such as drawings and schedules. However, a steelwork fabricator will not normally be involved in the process before the detailed design stage. It is worth noting that interpretation of the word ‘design’ therefore varies significantly.

The list of stages presented below is general, and it should be recognised that in practice the programme of activities varies widely. The sequence for a specific project will frequently differ from the general case:

1. Feasibility
2. Outline proposals
3. Scheme design
4. Detail design
5. Production information
6. Bills of quantities
7. Tender action
8. (Contractor's) project planning
9. Operations on site
10. Completion (and handover)
11. Feedback

Designing to facilitate construction requires a well-managed design process throughout these stages. The designer must address the following six points, which are addressed in the Sections that follow:

- recognise the complexity of the design process
- establish an appropriate design team
- agree information and programme
- coordinate contributions
- manage the interfaces
- control design development.

2.3.1 Complexity of design

Design is a complex process, and it continues to grow in complexity as knowledge increases. Contributions are made by a large number of individuals from a broad range of organisations, necessitating a continual exchange and refinement of information. The lead designer must aim to provide as accurate and as complete information as possible to the relevant parties on time.

The design of the frame itself has in many ways become simpler in recent years, with the widespread use of computers. However, although software enables rapid and accurate calculation of forces and moments, it is essential that a qualitative feel for how structures behave is not lost as frames grow in complexity⁽⁵⁾.

2.3.2 The design team

The most successful projects are often those in which the client has a long term relationship with the design consultants and trade contractors. When such 'partnering' is not adopted, the client must choose a suitable method for selection of a designer and the formation of a design team.

The construction scenario takes a different form depending on the type of contract adopted. The three most common types of contract use one of the following approaches, and the corresponding teams are as noted:

Traditional, in which the client appoints an ‘Engineer’ (to undertake the design and to ensure satisfactory construction) and a ‘Contractor’ (to undertake the construction).

Design and build, in which the client appoints a single contractor, or consortium, to undertake both the design and construction of the works. One of the advantages of this type of contract is that the contractor and/or subcontractors are more likely to be involved from an early stage, so that their construction experience can be incorporated in the design.

Construction management, in which the client appoints a project manager, who in turn appoints the other team members on behalf of the client. Because specialist steelwork contractors usually undertake some, if not all, of the steelwork design, they should be appointed early.

2.3.3 Agreement of information / programme

A programme should be compiled and agreed, so that dates by which information is required are fixed. The lead designer for a zone should ensure that every aspect of the work is detailed fully and correctly. A system should be established to carefully monitor drawing and schedule revisions, to ensure that all parties are working to the latest information.

The client’s representative, for example the Engineer or Project Manager, must make decisions to proceed at key points, or inform the client of decisions to be made. At each stage through the design process, he should liaise with the design team to assemble all the necessary information, agree the content, and sign off the stage or package.

Terms such as ‘complete information’ or ‘full and final information’ are often used in the context of the design programme, in an attempt to ensure that information is ‘frozen’ at key points. The objective of this is to permit construction to proceed without interruption beyond that date. Sometimes the process is necessarily more complicated, and the following guidance should be considered:

- Construction work, on or off-site, cannot proceed without construction issue information. How this corresponds to earlier information, upon which the tender was based, is a matter for clarification in the contract, but only the construction information is important as far as progressing construction work is concerned.
- All contracts allow the construction issue information to be altered at a later date if necessary, and such variations must be executed by the contractor. The latter will however be entitled to appropriate additional payment and/or a revised programme.
- If, at a given point in time, the construction information is known to be incomplete, work can generally progress provided areas of missing or preliminary information are identified and they are not on the critical path. Clarity is essential, since information which appears to be complete, but is actually not so, is a major source of contractual disputes.

Often a designer will have difficulty in determining the detailed requirements of the site. A contractor may find that the designer does not understand the constraints imposed by site conditions. A clear understanding between the relevant parties is necessary to ensure that information supply is integrated with construction need.

Modern working practices, with ever decreasing timescales, have affected the transfer of information between the structural designer and steelwork contractor. The use of CAD as part of a factory production system means that the fabricator can rapidly build-up a model of the frame, *but* he requires complete information before he can start. Steel must be ordered early, and connection information can no longer be considered as secondary. Connection design and detailing may take place in the first two weeks of the steelwork contractor's programme.

In Section 1 of the *National Structural Steelwork Specification* (NSSS)⁽⁶⁾ details are given of information which should be supplied to the steelwork contractor for different contract scenarios. Similar recommendations can be found in Appendix C of ENV 1090-1⁽⁸⁸⁾. This information will be required early in the project because the steelwork is an early trade on site. As an example, consider the typical case when design and detailing of the connections is to be carried out by the steelwork contractor after member design has been performed by the consulting engineer. The NSSS states that information concerning the following 15 points must be supplied in such a case:

1. A statement describing the design concept
2. Design drawings
3. Environmental conditions which may affect detailing
4. The design standards to be used for connection design
5. Any part of the steelwork where the manufacturing processes must be restricted, for example plastic hinge locations
6. Details of any dynamic or vibrating forces, and members subject to fatigue
7. The forces and moments to be transmitted by each connection
8. In the case of limit state design, whether loads shown are factored or unfactored as defined by BS 5950⁽⁸⁵⁾
9. Positions on the structure where additions and stiffeners are required to develop the combination of local and primary stresses, and where notching may affect member stability
10. Any grades of bolt assemblies and their coatings which are specifically required
11. Details of fixings of bolts to the foundations for which the consultant is responsible, or a statement indicating that the steelwork contractor has to design these items and prepare a foundation plan drawing
12. Requirements for any particular types of fabrication details and/or restrictions on types of connection to be used
13. Details of cutouts, holes or fittings required for use by others
14. Cambers and presets which have to be provided in fabrication so that continuous frames and other steelwork can be erected to the required geometry
15. Connections where holes cannot be punched

It is interesting to note that recent and future developments, for example the use of semi-rigid or composite connections, will have implications on this traditional procedure. It may no longer be possible to divorce member and connection design, because of their interdependence.

2.3.4 Coordination

Contributions to the design are frequently drawn from a wide variety of sources within many organisations. Different contractual arrangements may be adopted, as discussed above. Each organisation will have its own objectives which, although sympathetic to the project as a whole, will often override it. This problem may be especially pronounced with specialist designers, who are only concerned with one small part of the project.

When a ‘construction led’ approach is adopted, consideration of the construction programme should reveal the principal designers for each stage of the project. Formal start-up meetings at key stages can be used to agree programmes, details etc. During these meetings critical tasks must be identified, and communication can be fostered and encouraged. Because the contributions of different organisations may run in parallel careful planning is needed, with substantial cross-referencing between individual designers to ensure compatibility.

2.3.5 Interfaces

Physical interfaces relate to the features of the building, and may occur between components, systems, or zones. If maximum benefit is to be derived from a construction strategy based on zones (see Section 4.3), a clear separation of systems crossing the zones must be made. Lead designers of adjacent zones should negotiate with one another to establish:

- the line of an interface
- who has primacy in coordinating the design
- information requirements for both parties
- the policy on tolerances.

Sections 6 and 7 of these guidelines give detailed information concerning interfaces with both structural and non-structural components. The extensive information given reflects the importance that the interfaces may have in dictating the overall building cost.

2.3.6 Design development

Design development must be carefully controlled because primary designers require large amounts of information from various sources. *Communication of structural design*⁽⁴⁾ identifies possible key stages of Scheme Design and Detail Design. Information required at each of these stages, according to that particular document, comprises:

Scheme Design information : ‘Investigate alternative detail solutions to the basic structural problems (including alternative design by the contractor). On basis of foregoing, refine and develop outline proposals and produce all structural information leading to cost check of the scheme design.’

Detail Design information : ‘Develop proposals from Scheme design information and produce necessary detail information.’

Agreements and approvals required during these two stages are also given⁽⁴⁾ . Similar requirements are identified in other documents⁽⁷⁾ . The Institution of Structural Engineers recommend that the brief should not be modified after the

Scheme Design stage. They also note that any changes in location, size, shape or cost after the Detail Design stage will result in abortive work.

Allowances for design development may be built-in to the design programme to cope with the sorts of problem which, often arise in practice. There may be periods during which a two way exchange of information between the design and construction teams is possible, but ever decreasing timescales are reducing the possibility for such overlaps. Unfortunately, even with disciplined procedures abortive work often takes place.

ACTIONS - Planning for construction

The designer should:

- carry out a thorough investigation
- plan for essential site production requirements
- plan for a practical sequence
- plan for simplicity of assembly
- plan for logical trade sequences
- recognise the complexity of the design process
- establish an appropriate design team
- agree information and programme
- coordinate contributions
- manage the interfaces
- control design development

2.4 Further reading

(For further information, see Section 9, References)

Buildability: an assessment⁽³⁾. Buildability is defined, and how to achieve it is explained in general terms. The guide is not material specific.

The successful management of design - a handbook of building design management⁽⁸⁾. This is one of several relevant publications produced by the University of Reading. General management issues are discussed, considering both design-led and production-led approaches for the industry.

Communication of structural design⁽⁴⁾. Stages in the design process are identified and defined, giving details of work to be undertaken. This document is linked to the RIBA plan of work (reference 7), and includes extensive tables.

Aims of structural design⁽⁹⁾. Addresses needs identified following the Ronan Point collapse, by qualitatively discussing the purposes of design, the processes by which the designer seeks to achieve them, and various considerations that affect his actions.

RIBA plan of work⁽⁷⁾. Defines 12 stages in the development of a project. For each stage identifies the purpose of the work and decisions to be taken, tasks to be undertaken, and people directly involved. Key stages beyond which changes should not be made are identified.

The National Structural Steelwork Specification for Building Construction, 3rd edition.⁽⁶⁾ The aim of this document is to achieve greater uniformity in contract specifications. It covers materials, drawings, workmanship, and quality assurance amongst other issues. Section 1 outlines the information which should be supplied to the steelwork contractor for different types of contract.

Commentary on the third edition of the National Steelwork Specification for Building Construction ⁽¹⁰⁾. The title of this book is self-explanatory.

Quality management in construction - contractual aspects⁽¹¹⁾. Discusses different construction contracts, and the invoking of quality systems.

3 DESIGNING FOR CONSTRUCTION

3.1 Design principles

Generally, the designer should adhere to the following four principles to facilitate construction:

- carry out a thorough design
- detail for repetition and standardisation
- detail for achievable tolerances
- specify suitable components.

These principles are taken from CIRIA guide **SP26**⁽³⁾. Their application to the design of steelwork is highlighted in the Sections that follow.

To assist the application of these four basic principles, examples of existing practice are often useful to both clients and designers. Examples help the assessment of possible alternatives. For clients, a portfolio of photographs and descriptions is useful. British Steel have built up a catalogue of case studies, and these are summarised in Appendix A. For structural designers, it is useful to have an indication of the weight of steel per unit area (or volume) that might be expected for the chosen framing plan. Appendix A also gives guidance on typical weights for various building forms.

3.1.1 Thorough design

A thorough steelwork design should preferably be completed before commencing construction. Unfortunately, this rarely happens in practice for a variety of reasons, and the best a designer can do is often to try and minimise late changes. These are particularly expensive to accommodate if site modification is required.

A thorough design is one which includes consideration of how the frame could be erected. The designer has an obligation to consider erection under the CDM regulations (see Section 5) , and he must convey relevant information to the client. Information to be passed on to the site team must include:

- the method of erection the designer assumed
- requirements for temporary bracing or propping, and conditions for their removal
- features which would create a hazard during erection.

3.1.2 Repetition and standardisation

With increased automation in both design and fabrication processes there is an argument that repetition, which is a form of standardisation, is less important today than in the past. However, standard, and perhaps more importantly, simple details should be adopted wherever possible in order to reduce fabrication work and keep erection simple.

For example, increasing the serial size of a member to enable the adoption of a standard connection, with no need for stiffening or strengthening, is one way of simplification and is often of economic benefit. Simple standard solutions should

be preferred, unless complex or unfamiliar forms of construction are necessary or appropriate for a specific situation (e.g. composite stub girders may be economical for relatively large spans in a highly serviced building with a restriction on inter-storey height, see Section 3.3).

3.1.3 Achievable tolerances

There are several reasons for specifying tolerances (see Section 8), and these may be split into two categories. The first is to ensure that the actual deviations or imperfections of the completed frame do not exceed those allowed for in the design. Secondly, frame members and other components should fit together correctly when they have been fabricated and erected within correctly specified tolerances. The latter requirement imposes more onerous tolerances, particularly at interfaces between different components such as steel and glazing. The designer should specify tolerances that will ensure that these requirements are satisfied. Appropriate values for most situations are given in the NSSS⁽⁶⁾.

It is also essential that the designer specifies tolerances which can be achieved, recognising the limits of tolerances attainable in normal site construction. Problems of fit often occur at interfaces between different products, methods of construction, materials and methods of manufacture. These matters should be considered and allowed for by developing suitable jointing methods at the design stage.

The designer should also consider the consequences of assembly sequences; when pre-fabricated items are built in, differences between fine factory tolerances and those of site construction must be considered.

3.1.4 Suitable components

The designer should specify components which are suitable for the proposed application. Suitability will always mean being adequately robust, but other issues may also need to be considered. For example, the cold formed sheeting used to form composite slabs must be light enough to be manhandled into position, and strong enough to be walked on during erection. In addition to hindering construction, an unwise choice of component may result in increased maintenance costs, for example the cost of replacing an item with an inadequate design life.

3.2 Frame types

Basic design decisions taken at a very early stage can have significant implications on the ease of construction. The first choice is usually whether the frame will be braced or unbraced. The inclusion of bracing members may be precluded by criteria imposed by the client.

A braced frame includes members that provide positional restraint to other members, thus stabilising the frame, and that distribute horizontal loads to the supports (see Figure 3.1). The bracing system may comprise steel members, for example diagonals joining the frame nodes, acting in both horizontal and vertical planes. Alternatively, building components such as floors, shear walls, stair wells and lift shafts acting in isolation or together with steel members may be used. Such components may serve as bracing by acting as a diaphragm, but to achieve this, components must be adequately tied together; if floors are constructed using precast concrete units, transverse reinforcement suitably anchored into the units will be required.

The bracing system is used to form a ‘stiff box’, to which the remaining structure can be attached. When the bracing comprises a component such as a concrete lift shaft, which is not complete at the time of erecting the first steel members, temporary steel bracing may be needed to allow steelwork erection to progress (see Section 4.2.4).

In an unbraced frame, horizontal loads are resisted by the bending stiffness of the frame members. These must therefore be joined together with rigid connections to provide continuity. Again, depending on the construction programme, temporary bracing may be needed to form a ‘stiff box’.

Different ways of providing stability and resisting horizontal loads are shown schematically in Figure 3.1. Implications of the designer’s choice at this stage are given below.

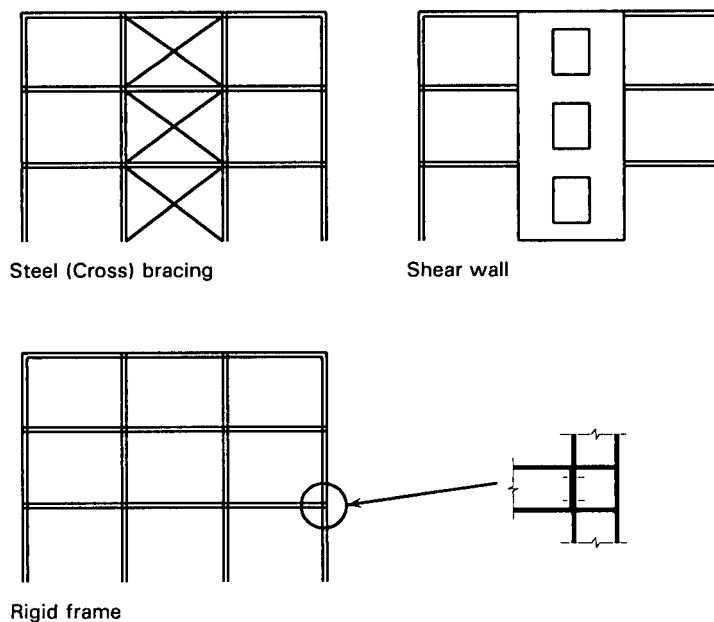

Figure 3.1 *Ways of providing stability and resisting horizontal loads; braced frames (with steel bracing or a shear wall), unbraced frame (relying on member and connection rigidity)*

Steel bracing

The advantage of adopting steel bracing members is that the steelwork package is self contained. The frame does not rely on any other elements (which may be the responsibility of another party) for stability. However, the inclusion of ‘vertical’ bracing members may be precluded by restrictions imposed by the client. Internal bracing members reduce the adaptability of the interior space (by preventing openings being made in certain locations), and bracing members around the perimeter of the frame may interfere with glazing requirements.

Other bracing

The use of stiff concrete or masonry elements enables some or all of the steel bracing members to be eliminated, but can lead to problems of responsibility; although the steelwork designer has the necessary load information, he may not want to design these secondary elements. Also, connections between steel and concrete or masonry elements may be difficult (see Section 6.2). Programming

must allow for the differences in speed of construction of steel and concrete or masonry elements. Temporary steel bracing is often required during construction as a result of connection or programme difficulties. Restrictions imposed by the client may prohibit the use of this type of frame (see above).

Rigid frame

Bracing is avoided when lateral loads are resisted by the frame members themselves. The members must be joined using rigid connections. The disadvantages of adopting a rigid frame are the complexity of the connections, and the need to complete these connections as erection progresses. The need for rigid connections can also result in relatively heavy columns, thereby increasing the frame cost.

Local bracing

As well as overall bracing to provide frame stability, local bracing may be used to provide member stability. This may be necessary at plastic hinge locations, or for compression members (see Figure 3.2).

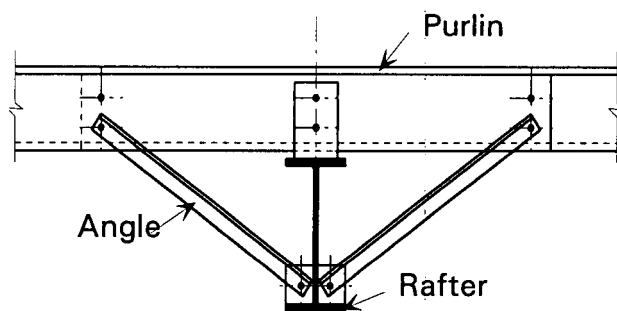

Figure 3.2 *Bracing to locally restrain a member in a portal frame*

Implications of the choice of frame type are summarised in the following 'Key Points'.

KEY POINTS - Frame types	
Braced	Unbraced
<ul style="list-style-type: none"> • Restricts location of openings • Generally less expensive 	<ul style="list-style-type: none"> • Client freedom • More expensive

3.3 Floor systems

For multi-storey commercial buildings, a range of steel and composite floor systems is available to the designer. The different systems are illustrated in Figure 3.3.

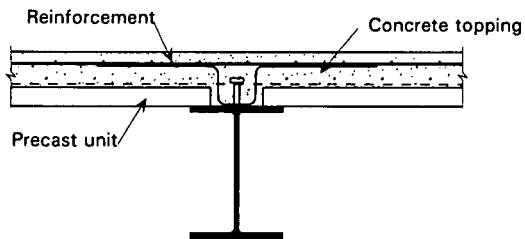

a) Steel beam and precast slab

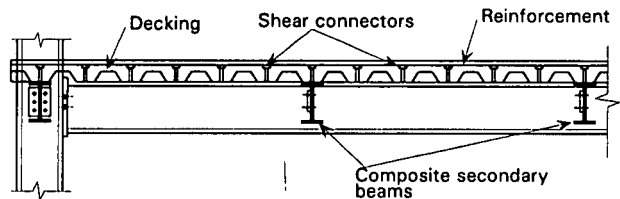

b) Composite beam and insitu composite slab

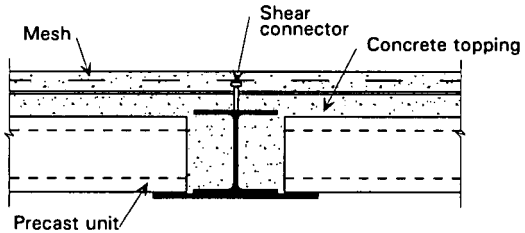

c) Slim floor beam and precast slab

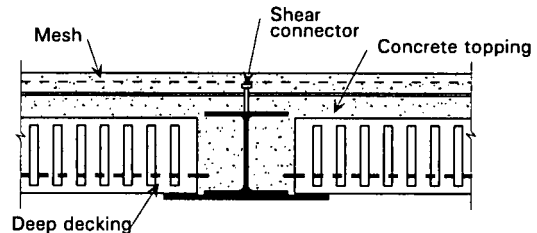

d) Slim floor beam and deep composite slab

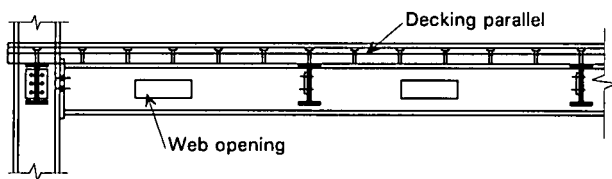

e) Composite beam with web openings

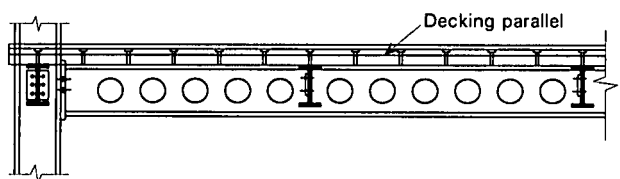

f) Composite cellular beam

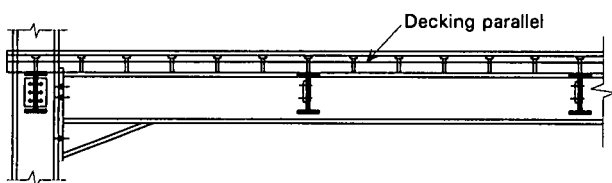

g) Haunched composite beam

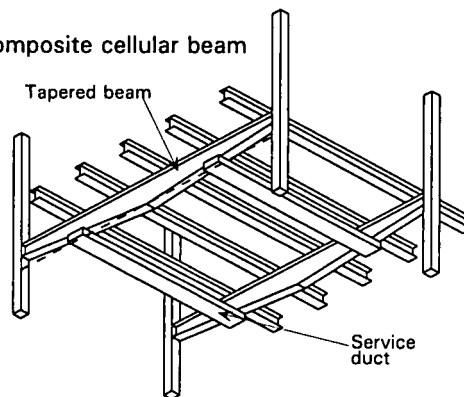

h) Composite tapered girder (viewed from below)

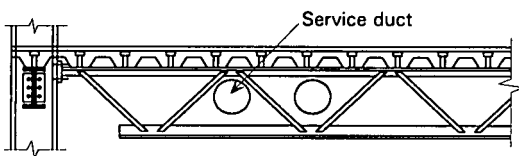

i) Composite truss

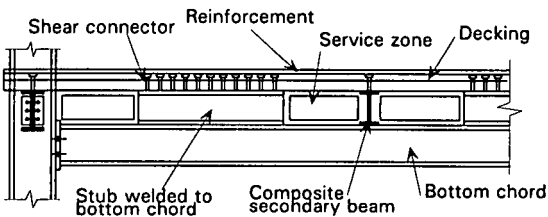

j) Composite stub girder

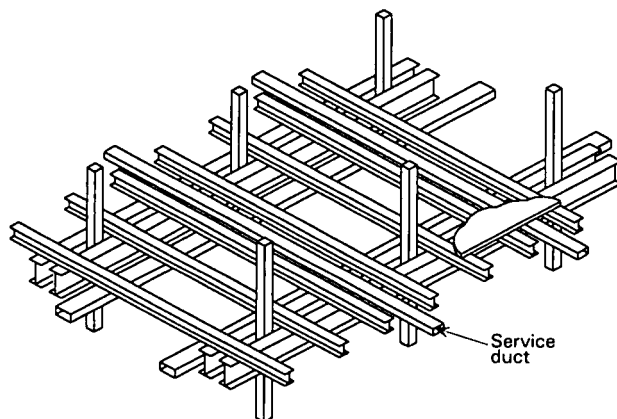

k) Parallel beams (viewed from above)

Figure 3.3 Floor systems

An economic comparison of various options, including the benefits of speed of construction, is presented in the SCI publication *Comparative structure cost of modern commercial buildings*⁽¹²⁾. The total structure cost for each system should not be considered in isolation from the overall building cost. Structure costs vary between 12% to 18% of the overall building cost, and time related savings, ease of service integration, cost of cladding etc. are also important. The use of a more expensive floor system may be justified by savings in one or more of these areas. Total building cost per square metre of floor area varies between approximately €50 to €80 for a building with a typical developer's specification, depending on the floor system. For a prestige building the cost is between €30 to €90. Prices were correct in 1992. Table 3.1 lists some of the different floor systems, giving the relative merits of each option.

Table 3.1 *Floor systems - relative merits*

Construction	Span (m)	Familiar	Erection	Span to depth	Service integration	Fire resistance
Steel beam & precast slab	6 - 9	●●●●●	●●●	●	●	●●●
Composite beam & in-situ composite slab	6 - 12	●●●●●	●●●●●	●●●●●	●●●	●●●
Slim floor beam & precast slab	6 - 10	●●●	●●●	●●●●●	●●●●●	●●●●●
Slim floor beam & deep composite slab	6 - 10	●●●	●●●●●	●●●●●	●●●●●	●●●●●
Composite beam with web openings	9 - 15	●	●●●●●	●●●●●	●●●●●	●●●
Composite castellated or cellular beam	9 - 15	●●●	●●●●●	●●●●●	●●●●●	●●●
Haunched composite beam	12 - 20	●●	●●●●●	●●●●●	●●●●●	●●●
Composite tapered girder	10 - 18	●	●●●●●	●●●●●	●●●●●	●●●
Composite truss	12 - 20	●	●	●●●●●	●●●●●	●
Parallel beams	10 - 15	●	●●●●●	●●●●●	●●●●●	●●●
Composite stub girder	10 - 18	●	●	●●●●●	●●●●●	●●●

Key:

●●●●●	Good	●●●	Average	●	Poor
●●●●	Above average	●●	Below average		

Alternatives which require more care during erection than straightforward beams generally suffer from one or more of the following problems:

- beams which rely primarily on the concrete to form the top flange need propping during construction
- a lack of lateral stability may necessitate the use of a lifting beam
- a lack of robustness may necessitate extra care during transportation and on site.

When precast concrete units are used the erection sequence must ensure that they are placed alternately in adjacent bays. This prevents excessive torsion being applied to the beams. The specific benefits of options employing metal decking are discussed separately in Section 6.4.

3.4 Connections

Basic materials account for approximately 40% of the cost of a steel frame. The remaining 60% is primarily related to joining and handling members; it may be further broken down into 30% for connections, 10% for general handling, and 20% for connections related handling. Connections therefore affect approximately 50% of the total frame cost⁽¹³⁾.

Considerable savings have been made in recent years in the UK, where standard connections are now widely adopted. Standard details are given in the 'Green Books' published by the SCI/BCSA Connections Group(14,15,16). Some examples of standard details are given below.

The following general points should be considered when designing and detailing the connections(7):

- the connection arrangement should allow safe and rapid erection
- where possible, use one connection type per principal joint type (for example beam to column) on a given project
- locate column splices in general at every alternate floor
- provide a hole 1 m above beam connections for the attachment of safety lines.

3.4.1 Simple beam to column connections

Details and design procedures for simple connections are given in *Joints in simple construction, volumes 1 and 2*, to which reference should be made for more details^(14,15). General information is given below.

A typical standard double angle web cleat beam to column connection is shown in Figure 3.4. This type of connection enables considerable site adjustment. Both sets of bolts are placed in clearance holes to allow adjustment in two directions before the bolts are tightened. Packs can be used to provide further adjustment if required. Web cleats are not generally used for skew connections.

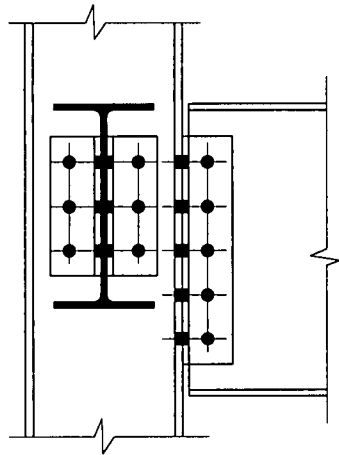

Figure 3.4 *Double angle web cleat connection*

A typical standard flexible end plate connection is shown in Figure 3.5. This type of connection has less facility for site adjustment than web cleats. Care must be taken with long runs of beams, as the accumulation of cutting and rolling tolerances can lead to columns being pushed out of plumb. This problem can usually be overcome if the beams are accurately cut to length and a shorter beam with packs is detailed at regular intervals, for example every fifth beam.

Difficulties, and therefore time delays, can be encountered on site when a pair of beams either side of a column web share a common set of bolts. When such a detail is adopted for larger beams, it may be necessary to provide some form of support during erection, for example, a seating cleat.

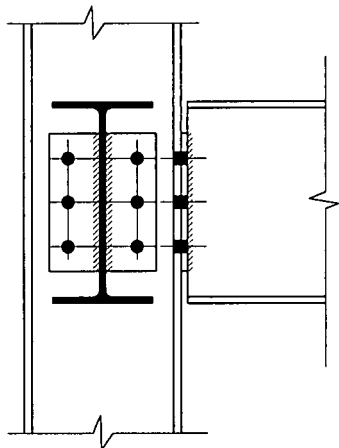

Figure 3.5 *Partial depth flexible end plate connection*

Fin plate connections are of the configuration shown in Figure 3.6. The simplicity of this type of connection offers considerable benefits both on site and during fabrication. Once the beam has been swung roughly into position it can be quickly aligned using a podger spanner (which has a tapered handle to facilitate this). As with other types of connection, the insertion of approximately one third of the total number of bolts is then usually sufficient to secure the beam and allow the crane hook to be released.

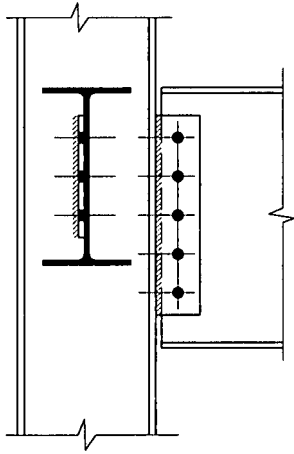

Figure 3.6 *Fin plate connection*

3.4.2 Moment resisting beam to column connections

Standardisation has also been achieved for moment connections, despite the fact that there are many more possibilities than for simple connections. Moment connections are often subject to the added complexity of stiffeners. Capacities for recommended details are given in *Joints in steel construction - moment connections*⁽¹⁶⁾, to which reference should be made for more information.

Typical bolted end plate beam to column moment connections are shown in Figure 3.7. In terms of erection this is no different from a flexible end plate connection, unless stiffeners, which may restrict access for bolting up, are present.

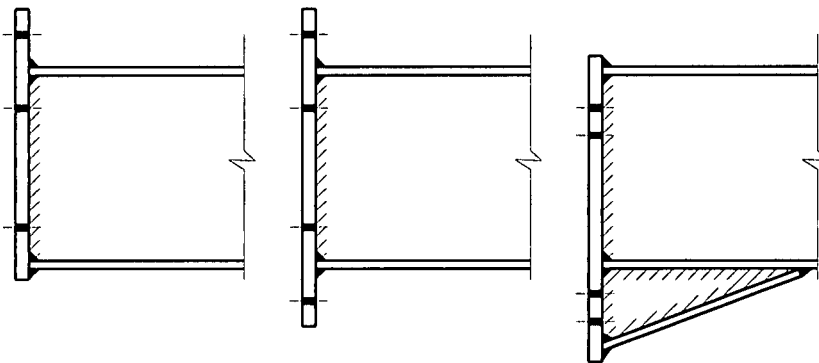

Figure 3.7 *Typical end plate moment connections*

So-called wind moment connections are a special type of moment connection which use thin flush or extended end plates. 'Wind moment frames' are designed assuming the connections act as pins under gravity load but as rigid connections under lateral load. This type of connection is currently used in frames which are unbraced about the major-axis⁽¹⁷⁾. A similar connection can be used in braced frames to provide semi-continuity at the joints⁽¹⁸⁾. The thin end plate, which is limited in thickness to approximately 60% of the bolt diameter, ensures adequate ductility. Local stiffening of the column can normally be avoided because of the limited moment capacity of the connection. Erection details are as for any other end plate connection.

Beam to column connections may also be either shop welded or site welded. Typical examples of each are shown in Figure 3.8. With a shop welded detail, the main welds are made in a controlled factory environment. A straightforward bolted site splice then suffices to join the beam-stubs and beams. Because of the amount of work involved, this type of detail is generally more expensive than a straightforward bolted connection. Site welded moment connections are used extensively in the USA and Japan, where continuous unbraced frames are a popular choice for buildings in seismic zones. Site welded connections are currently little used in the UK. As well as a need to provide temporary brackets and bolts to hold members in position while they are welded, they require provision of access equipment and suitable weather protection during welding and inspection.

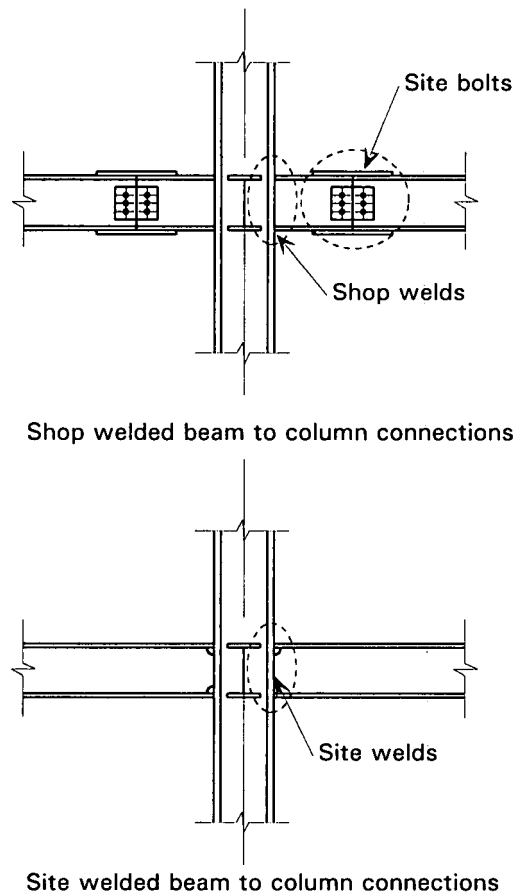

Figure 3.8 Shop and site welded beam to column connections

3.4.3 Structural integrity

All floor beam to column connections must be designed to resist a tying force of at least 75 kN according to BS 5950: Part 1⁽⁸⁵⁾. This magnitude of force can be carried by the simplest of cleated connections⁽¹⁴⁾. However, for certain tall, multi-storey buildings it will be necessary to check connections for larger tying forces to satisfy the structural integrity requirements of BS 5950.

Generally the tying capacity of a web cleat connection is adequate, mainly because of its ability to undergo large deformations before failure. Procedures for calculating this capacity are available^(14,15). If a connection is unable to carry the necessary tying force, for some floor types (for example in-situ reinforced concrete) extra capacity can be achieved by considering the in-plane capacity of the slab. This may carry all or part of the tying force back to the steel frame.

3.4.4 Splice connections

Simple column splices may be of the bearing or non-bearing type. Typical details are shown in Figures 3.9 and 3.10. In a bearing splice the loads are transferred from the upper to lower shaft either directly or through a division plate (or cap and base plates). This is the less complex type of splice, although when a cap plate is used it may interfere when erecting beams.

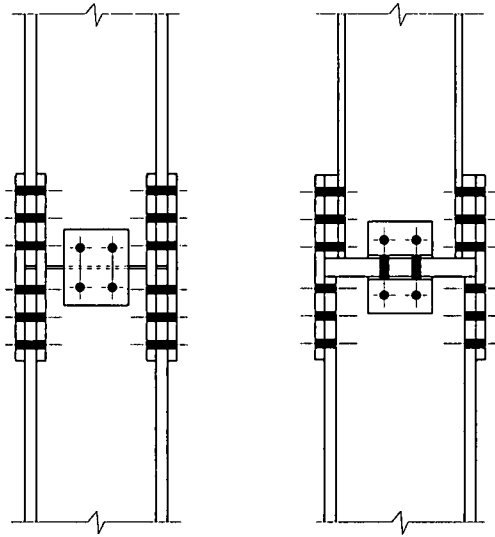
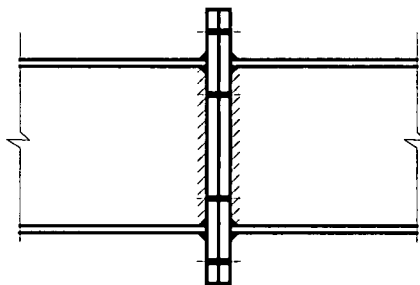
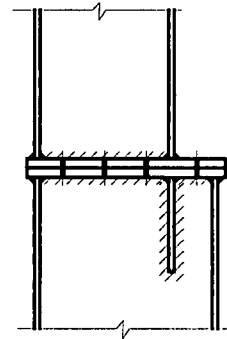

Figure 3.9 *Splices using bolted cover plates - details to accommodate either equal or different sized sections*



Extended both ways - beam



Different size - column sections

Figure 3.10 *Splices using bolted end plates*

Cutting a member square to its axis using a good quality saw in proper working order is generally sufficient preparation for direct bearing. An admissible tolerance for flatness is specified in the NSSS⁽⁶⁾, and reproduced in Figure 3.11. Machining should not normally be necessary, and any lack of contact between sections will be accommodated by local plastic deformation as loads are applied.

In non-bearing splices, loads are transferred via bolts and splice plates. Any bearing between the members is ignored, indeed a gap may be detailed. Preloaded bolts should be used to provide a 'friction grip' detail if the flanges may be subjected to alternating tension and compression, or when slip is unacceptable. This type of connection can be expensive, involving heavier connection components and increased site bolting. It permits independent adjustment for verticality of the individual column lengths.

Moment resisting splices may adopt bolted flange and web cover plates, bolted end plates or similar welded details. They are used for columns or beams where bearing is not the predominant force to be transferred.

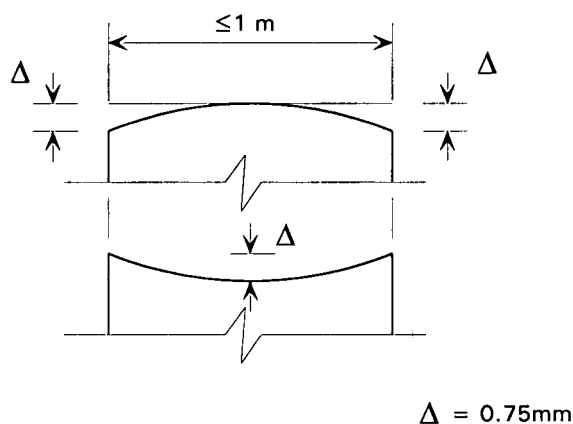

Figure 3.11 *Tolerance on flatness*

3.4.5 Connections to hollow sections

Various examples of site connections to hollow section members or sub-assemblies are given in Figures 3.12 to 3.14. Welding is generally used to connect members into sub-assemblies in the shop. The assemblies are then bolted together on site. The calculation methods used to design many of the site connections are basically the same as those used for any other type of connection in 'conventional' structural steelwork. However, for the shop connections between tubular members, the member size is often dictated by the ability to form an appropriate connection, and this must not be forgotten in a situation where member and connection design is carried out by different parties. Tube to tube connection design must be considered as an integral part of the member design process.

Calculation examples and design tables may be found in reference⁽¹⁹⁾, which is one of a series of guides published by the International Committee for the Development and Study of Tubular Structures (CIDECT). Information is also given in Eurocode 3 Annex K, which deals with hollow section lattice girder connections.

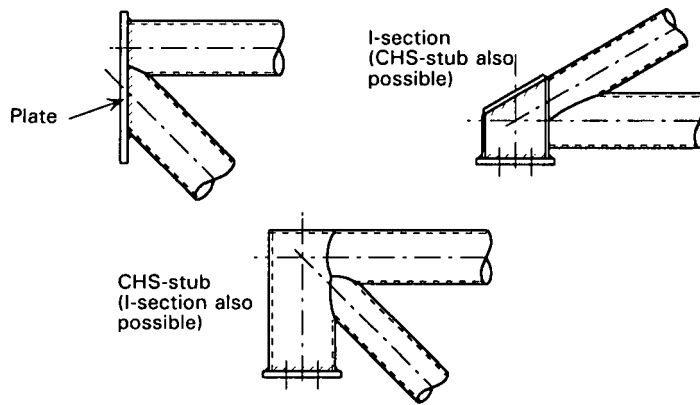

Figure 3.12 Bolted truss support connections

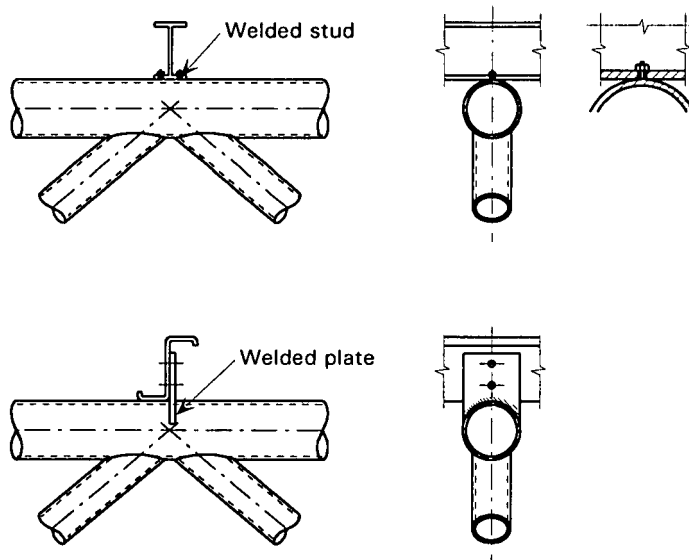

Figure 3.13 Bolted purlin connections

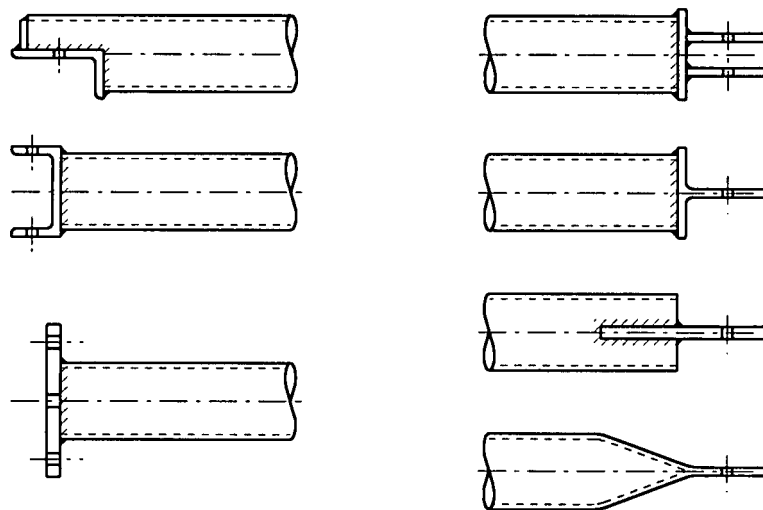

Figure 3.14 Bolted end connections

3.4.6 Column bases

Column bases are discussed specifically in Section 6.1. A typical detail for a nominally pinned base, which can nevertheless resist some moment, is presented in Figure 6.1. Bases capable of resisting substantial moments are heavier, with more extensive, and therefore more expensive, foundations. From an erection point of view, when extra bolts are required these may increase the likelihood of lack-of-fit problems, and difficulties in landing a column on the base. Control of frame deflections may also prove a problem when moment resisting bases are used, since columns will be smaller than in an equivalent frame with pinned bases. Information is also given in *Joints in simple construction, volume 2*, to which reference should be made for more details⁽¹⁵⁾.

3.5 Bolts

Bolts are discussed in the CIMsteel *Design for manufacture guidelines*⁽¹⁾, from which the following points are taken:

- preloaded bolts should be used where relative movement of connected parts (slip) is unacceptable, or where there is a possibility of dynamic loading, but not elsewhere
- the use of different grade bolts of the same diameter on the same project should be avoided
- washers are not required for strength with non-preloaded bolts in normal clearance holes
- when appropriate, bolts, nuts and washers should be supplied with a corrosion protection coating which does not require further protection on site
- bolt lengths should be rationalised
- bolts should be threaded full length where possible (see below).

Although connection details have been standardised, on a typical major project, 70 different bolts may still be used. With rationalisation, this number could be reduced by a factor of up to 10. The single largest reason for the number of bolt variations is the practice of part threading the bolts, and ordering them in 5 mm length increments. Fully threaded bolts, including preloaded bolts, are known to behave adequately in shear and are allowed by British Standards. Circumstances in which the use of fully threaded bolts may not be appropriate are relatively rare⁽²⁰⁾. Although there are potential minor extra manufacturing costs due to an increase in the average bolt length and a need for more threading, significant overall savings are possible when standard, fully threaded bolts are used:

- reduced prices due to bulk purchasing
- 'just in time' (JIT) purchasing
- no need to compile extensive bolt lists (giving details of bolt types and locations)
- smaller stock
- less handling due to reduced sorting
- faster erection
- reduced errors (therefore increased safety)
- reduced wastage.

Approximately 90% of simple connections could be made using M20, 60 mm long bolts. With a choice of three lengths, 95% of connections could be covered.

3.6 Welding and inspection

Welding and inspection are discussed in the *CIMsteel Design for manufacture guidelines*⁽¹⁾, to which reference should be made for more information. The following points provide a summary:

- good access is needed for site welding and inspection
- fillet welds up to 12 mm leg length are preferred to the equivalent strength butt weld.

In-situ welding is not normally preferred if a suitable bolted connection is possible. When in-situ welding is adopted, provision must be made for protection against inclement weather. Providing such protection may have programme implications, as well as the direct costs involved.

3.7 Corrosion protection

Corrosion protection is also dealt with in the *CIMsteel Design for manufacture guidelines*. The following points provide a summary:

- choose a protection system to suit the environment - don't protect if it's not necessary
- use a single coat system applied during fabrication if possible
- ensure compatibility with the fire protection system
- clearly distinguish between any requirements for decorative coatings and protection requirements.

Further information may be found in Section 7.7 of this document.

3.8 Interfaces

Interfaces occur between numerous components (structural or non-structural), and the steel frame. Although these components are often not the responsibility of the structural designer, they may have an influence on the frame and are therefore appropriate for inclusion in this guide. The final objective of 'construction led' design is to reduce the overall building cost, not the cost of individual items such as the steel frame. Several examples in Section 7 of this document indicate how a little extra spent on one item can produce a saving in overall cost. Building services are a particularly good example to consider (see Section 7.1).

Component interfaces often coincide with trade interfaces. To avoid potential disruption on site it is essential that responsibilities, and specifications, are clearly defined at an early stage. Both design and construction are affected, and the flow of information may be one or two way. All parties involved should have a responsible attitude to not compromise the work of others. 'Cooperation' will increase the overall efficiency of the project.

Getting the interfaces 'right' is essential when designing for construction. Considerable detail concerning the interfaces listed below is given in Sections 6 and 7 of this document:

Structural (Section 6)

- foundations
- concrete and masonry elements
- timber elements
- composite beams and floors
- precast concrete floors
- crane girders and rails
- cold formed sections.

Non-structural (Section 7)

- services
- lift installation
- metal cladding
- curtain walling
- glazing
- brickwork restraints
- surface protection
(corrosion and fire protection).

ACTIONS - Designing for construction

The designer should:

- standardise and repeat components
- specify appropriate tolerances
- specify suitable components and procedures
- consider the overall building cost, not just the frame cost

3.9 Further reading

(For further information, see Section 9, References)

The National Structural Steelwork Specification for Building Construction, 3rd edition⁽⁶⁾. See Section 2.4.

Design for manufacture guidelines⁽¹⁾. A companion document to these guidelines, considering fabrication rather than construction. Its aim is to bring a degree of understanding of the manufacturing implications to the early design phases of a project.

Buildability: an assessment⁽³⁾. See Section 2.4

Comparative structure cost of modern commercial buildings⁽¹²⁾. Different frame options are considered and costed. Gives good guidance on different beam and slab possibilities. All aspects of cost, including time related savings, are considered.

Joints in simple construction, vol 1 and vol 2 ^(14,15), and *Joints in steel construction: moment connections*⁽¹⁶⁾. Authoritative design guides for structural steelwork

connections. The books promote the use of standard design methodology and standard connection details.

Construction led⁽¹³⁾. Series of articles published in *Steel Construction Today* and *New Steel Construction* in 1993. Informative articles covering various aspects of structural steelwork design, fabrication and erection.

Design guide for circular hollow section joints⁽¹⁹⁾. Valuable design information from the international committee which deals with tubular construction. Other guides are available from the same organisation.

Constructional steel design - an international guide⁽²¹⁾. A collection of papers by various authors, providing an international view of steel and composite construction. Includes; material behaviour, element behaviour and design, dynamic behaviour, construction technology and computer applications.

Verifying the performance of standard ductile connections for semi-continuous steel frames⁽²²⁾. Describes a series of tests undertaken to establish details for a family of standard ductile connections.

A new industry standard for moment connections in steelwork⁽²³⁾. Describes the background to reference 16.

Design guidance notes for friction grip bolted connections⁽²⁴⁾. Considers analysis and design of HSFG bolted connections, including a description of bolt behaviour. The text is complemented by worked examples.

Steelwork design guide to BS 5950, vol 4, essential data for designers⁽²⁵⁾. Presents essential design data, not readily available elsewhere, that is useful to steelwork designers and fabricators.

Serviceability design considerations for low-rise buildings⁽²⁶⁾. Includes serviceability design guidance for roofing, cladding, and equipment such as elevators and cranes. Gives recommended maximum values for deflections, and considers human and machine response to vibrations.

4 SITE PRACTICE

The aim of this Section is to give the designer an appreciation of what will, or perhaps should, happen on site. Some of the information describes best *site* practice, and is therefore less directly relevant to the designer than the best *design* practice contained elsewhere in the document. Nevertheless, what will happen on site should be considered during the evolution of any design.

Careful planning of the site work is needed to ensure that a steel frame is erected to programme and within budget. The amount of work to be carried out on site should be minimised, since it is a less suitable and therefore more expensive environment for connecting members than the fabrication works (typically, work undertaken on site is between two and ten times more expensive than the same operation undertaken in the works).

It may be possible for the designer to reduce the amount of site work by specifying components such as fascia frames that are pre-assembled in the workshop. Similarly, some elements, such as components of walkways, may be connected together at ground level to form sub-frames prior to lifting into position. This reduces risk by reducing the work to be performed at height, and speeds up erection by reducing the number of lifts. The use of sub-frames may also facilitate erection, by increasing the rigidity of the items to be joined together 'in the air'. Care must be taken to ensure that sub-frames can be easily joined to other frame members.

Site work can also be reduced by eliminating the need for modifications to the steelwork on site. To achieve this it is essential that the designer supplies the necessary final design information to the steelwork contractor on time (as noted in Section 2). Late or revised information is one of the major reasons why modifications are required on site, causing projects to run late and costs to escalate.

4.1 General features of site practice

4.1.1 Delivery

The need for transportation to site leads to the imposition of certain limitations on the size of components. These limitations may be either practical, due to problems of handling or site access, or legal restrictions governing transport on public roads. Figure 4.1 provides a summary of the maximum dimensions of items which can be transported by road, with or without police notification and escort. Transport time increases considerably as requirements become more onerous; relative values are also indicated in Figure 4.1. The relative costs of the three alternatives vary in accordance with the time taken. More details are given in *Design for manufacture*⁽¹⁾

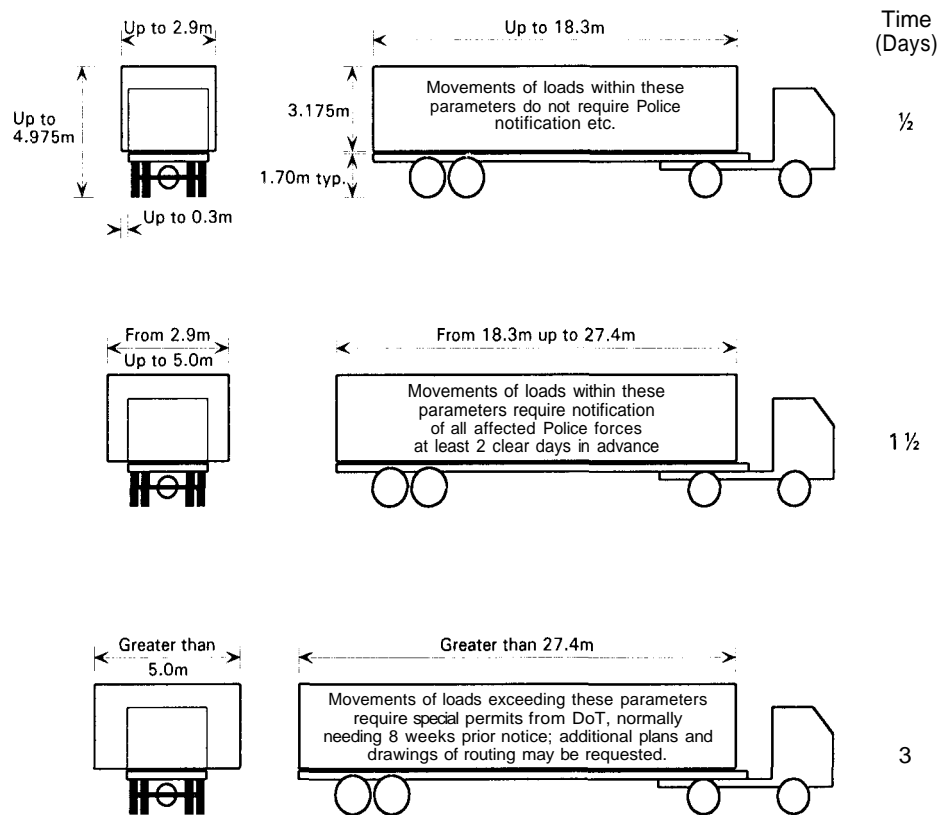

Figure 4.1 Road transport limitations

4.1.2 Storage

Handling of materials can be reduced by careful consideration of storage, with potential savings in both plant and labour costs. ‘Just in time’ delivery can be used to avoid double handling, provided deliveries are carefully planned; this may be essential on a congested site. It is worth remembering that ‘just in time’ on site does not necessarily mean leaving the fabricator’s workshop just in time. An intermediate off-site storage buffer may be used.

Material should be stacked in such a way that the items which are needed first are readily available without moving other material. However, some compromise may be necessary, since it is also desirable that the heaviest items are stacked nearest to the crane access (lifting capacity decreases with radius, see Section 4.2.1). Heavy loads should not be placed on top of underground services such as electrical cables, culverts or drains, which could be damaged by the weight.

The area set aside for storage must be firm and level. Wooden sleepers or other suitable material should be placed on the ground at regular intervals to act as bearers. Sufficient space must be left between stacked material for slinging and crane movements.

There are several methods of stacking steel members to give stability and optimise use of space. The most appropriate method depends largely on the uniformity of the steel and the overall dimensions of each component. Further aims of stacking are to avoid mechanical damage, and to prevent water build-up. Particular care is needed for members which are protected with an intumescent coating (which is generally less resistant to damage) so that the extent of on-site repair work is minimised.

4.1.3 Foundation interface

Accurate positioning and subsequent surveying of holding-down bolts prior to frame erection is essential. The recommendations made in *BS 5964: Part 1 Building setting out and measurement* ⁽⁸⁶⁾ should be adhered to. Tolerance values for the position and level of holding down bolts are given in the NSSS(@. These values, which are quantified in Section 8.3.1, are achievable with normal site practice. Further details concerning foundations are given in Section 6.1.

4.1.4 Sequential erection operations

The erection operations should be carefully planned by the steelwork contractor, and follow a logical sequence. Access restrictions to suit the main contractor's requirements will generally govern the sequence. Splitting the frame into zones for erection and alignment allows following trades to work in a zone whilst erection and alignment of the remaining steelwork progresses. An efficient sequence must also be carefully tied in with crange, which often dictates the speed of erection (see Section 4.3). The need to maintain stability of the part erected structure at all times must also be respected.

Knowing the sequence and timescale available, the steelwork contractor can assess his resource requirements, and determine how to provide access and safe working positions for the erection personnel. He should present all this information in an erection method statement, including a clear statement of the procedure for checking the alignment of the structure, and for handing it over to the client correct and complete.

The 'Key Points' that should be included in a contractor's method statement are summarised below. Of these, the designer is primarily interested in seeing a stable and safe erection sequence.

KEY POINTS - Method statements

The contractor's method statement should include the following information:

- Stable and safe erection sequence
- Plant resources
- Manpower and other resources
- Safe working positions and access
- Handover requirements

The following sections give a typical erection sequence for two common types of frame. Note however that although typical, these sequences must not be blindly adopted for specific cases; stability must be ensured at all times, and for some frames this will necessitate modifying the sequence.

Multi-storey braced frame

A typical (efficient) erection sequence for a multi-storey braced frame with composite floors is given below.

1. Erect columns after 'shaking-out' members i.e. steel is unloaded as a batch and individual items then distributed to positions from which they can be easily erected. 'Shaking-out' reduces crane hoisting and slewing. It is not needed when 'just in time' delivery allows erection straight from the delivery lorry.
2. Guy or prop columns to maintain temporary stability if necessary.
3. Erect lower floor beams.
4. Erect upper floor beams.
5. Place enough bolts to secure member (typically one third of final number).
6. Erect bracing members.
7. Plumb and bolt-up columns.
8. Tighten upper floor bolts.
9. Tighten lower floor bolts.
10. Tighten bracing member bolts.
11. Place decking bundles on lower floor.
12. Place decking bundles on upper floor.
13. Spread decking on upper floor and use as a 'shake-out' area for next tier.
14. Complete decking, edge trims and shear studs on lower floor.
15. When next tier steelwork is erected complete decking etc. on upper floor.

Reducing hoisting and slewing enables a greater number of pieces to be lifted by a crane during a given period (Figure 4.2). Making use of the decking avoids working on open steelwork at a height of more than two storeys (except at the edges of the frame), and eliminates the need for temporary access and loading platforms.



Figure 4.2 *South Quay station under construction (courtesy of British Steel)*

Braced portal frame

A typical erection sequence for a single bay braced portal frame is given below. Erection begins by creating a braced unit, or 'stiff box', to which other members are joined (see Section 3.2).

1. Erect a line of columns (or less if their stability is a problem).
2. Erect eaves beams between the columns.
3. Erect bracing members between the appropriate columns.
4. Erect opposing line of columns.
5. Erect corresponding eaves beams.
6. Erect corresponding vertical bracing.
7. Align and plumb the columns so that the rafter connections can be made (the bases of the columns may need to be restrained to prevent spreading when the rafters are erected).
8. Make the apex splice between the first pair of rafters (at ground level).
9. Erect rafters between the first pair of opposing columns, and bolt-up connections.
10. Repeat the above two steps for the rafters between the subsequent pairs of opposing columns.
11. Erect roof bracing between the appropriate rafters.
12. Tighten bracing bolts and re-tighten rafter to column bolts.
13. Fix end-bay purlins (with double span purlins, stagger joints so that some purlins extend into next bay to provide stability).
14. Fix purlins for subsequent bays.

For a multi-bay portal frame (Figure 4.3), erection should ideally begin with the central bay, and this should remain one line of columns ahead of the side bays. Side thrust from the rafters in the outer bays affects the plumb of the columns in the central bay. The deflected shape of the frame will alter as adjacent bays are erected and loads are progressively applied. This must be recognised when checking the frame position at different stages (see Section 4.1.6).

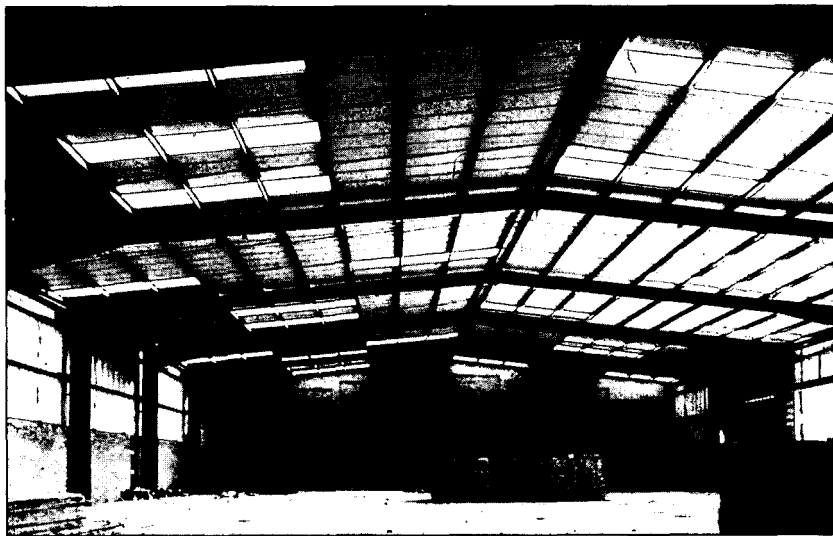

Figure 4.3 *Typical portal frame*

4.1.5 Piece size and count

The designer needs to consider limitations on piece size (weight, height and length) which are imposed by the workshop capacity. Handling, painting and galvanising may all need to be considered(').

For lifting on site, items fall into one of two categories; those which can be lifted and positioned by hand, and those which require a crane. Site conditions may dictate that the latter are minimised. If crane availability is a problem, the use of steel decking, which can be placed by hand, is preferable to precast concrete units requiring a crane for individual placement. The weights of some typical components found in a steel framed building are given in Table 4.1.

Table 4.1 *Weights of typical building components*

Item	Weight
Precast hollow concrete planks (8 m x 1.2 m x 0.2 m)	3000 kg
Steel decking (3 m x 1 m sheet)	40 kg
Concrete cladding (1 m ²)	600 kg
Composite cladding (1 m ²)	30 kg
Glazing (1 m ² x 5 mm, including frame)	25 kg
Prefab, stairs (1 m wide x 1 flight)	2500 kg
Rolled steel sections	see standard section tables

The site programme is highly dependent on the number of crane lifts which are needed. To reduce this number, maximum use should be made of pre-assembled units. A 'piece count' is useful for the designer to assess the number of lifts (see below).

Example of using a piece count

Consider a small industrial project comprising a shed, mezzanine and offices. A breakdown of the steelwork is given in Table 4.2.

Table 4.2 *Breakdown of project components*

Item	No of pieces	Piece weight (t)	Total weight (t)
SHED			
Columns	22	1.5	33
Trusses	10	7	70
Posts	5	0.2	1
Purlins	110	0.1	11
Rails	50	0.1	5
Bracings	10	0.2	2
Ties etc.	160	0.025	4
Subtotals	367		126

Table 4.2 *Continued*

Item	No of pieces	Piece weight (t)	Total weight (t)
MEZZANINE			
Columns	5	0.4	2
Beams	10	0.7	7
Subtotals	15		9
OFFICES			
Columns	8	0.875	7
Beams	20	1	20
Bracings	8	0.125	1
Subtotals	36		28
TOTALS	418		163

The pieces to be erected may be grouped together as shown in Table 4.3.

Table 4.3 *Erection timetable*

Item	Weight (t)	No of pieces	Erection rate (pieces per day)	Gang time (days)
Specials over 5 t	70	10	2	5
Items requiring crane	73	88	6	15
Items requiring MEWP*	16	160	20	8
Items erectable by 1 man	4	160	40	2
TOTALS	163	418		30

* MEWP stands for mobile elevated working platform

From the tables, it can be seen that the rate of erection for the heaviest items, specials over 5 t, is 14 tonnes per gang day (5 days is needed to erect a total of 70 t). This is much higher than the two tonnes a day estimated for the lighter pieces. Hence, for example, the introduction of a lightweight fascia around the shed might only add another 10 tonnes, but could possibly add a week to the erection period if the components were assembled 'in the air'. Prefabrication might be appropriate in such a situation.

4.1.6 Surveying and aligning the structure

The normal procedure for achieving and checking the line and level of the frame consists of an interaction between the site engineer and the erection gang. The engineer may use various items of equipment to check the frame position:

- theodolite
- optical level
- EDM (electronic distance meter) - used in combination with a theodolite. Alternatively, a single unit (*complete* or *total station*) performs the same tasks
- damped plumb bob
- piano wire
- laser level.

Surveying should be carried out in accordance with BS 5964 Building setting out and measurement⁽⁸⁶⁾. A secondary 'bench-mark should be established in the vicinity of the columns and its level agreed. It should be positioned to avoid disturbance.

The gang moves the frame into a position which is acceptable to the checking engineer, using equipment such as:

- a crane
- jacks
- wire pullers (for example Tirfor)
- turnbuckles (to tension cables)
- wedges.

The gang then firmly bolts up the frame. Some local corrections may be necessary to overcome lack of fit created during the process, but the gang rarely returns to a frame once it has been aligned and bolted up.

Columns

Columns are normally located on laminated steel packs set to level (these packs can usually be left in position under the baseplate)(@. The columns can then be moved around on a horizontal plane to achieve the desired alignment. The position of a reference line, offset from the column centerline to give a clear sight, should be marked and agreed with the client's representative. This line is used either to string a piano wire or to set-up a theodolite, so that 'transverse' column positions can be adjusted. Running dimensions from the building end may be used to adjust longitudinal positions. Relying on column to column dimensions is not appropriate because of the tendency of the frame to 'grow'. Packs may be introduced between beams and columns to accommodate any (small) lack of fit.

Having correctly positioned the column bases for line and level, the columns are checked for plumb. A theodolite can be used to check against a ruler held on the outside edge of the columns, or simply to sight the outside edges themselves. Holding a ruler on the column centre lines, to eliminate the effect of rolling errors, is not generally necessary. Alternatively, a heavy plumb bob hung on a piano wire may be used. A simple damping arrangement should be adopted, such as a bucket of water into which the bob is submerged. This arrangement has the advantage over a theodolite that repeated checking does not require resetting the equipment. Optical or laser plumbing units, which are particularly useful for checking multi-storey frames, are also available. On larger sites, EDMs are increasingly used to check column alignment and plumb.

Beams

Beam levels should only be checked at points specified in the NSSS - primarily at connections to columns. These are the only points where adjustment is possible within a floor. In many cases relative levels within a floor are of more importance than absolute levels; the reasons for limiting deflections must be considered (for example to allow attachment of cladding panels). Relative levels of adjacent beams should only be checked at corresponding points, for example supports, mid-span, the tips of cantilevers. Deflection limits specified in the NSSS are appropriate when the frame is checked under the self weight of the steel alone⁽¹⁰⁾.

Frame movement

It is important that all parties, including the designer, have a clear understanding of how a frame will deflect, and the limits of adjustments which can be made to the erected structure. A frame moves as adjacent bays are erected, and load application progresses. An understanding of the movement that will occur is necessary for the designer to produce a 'buildable' design, and to avoid conflict on site.

The designer should recognise that members may not be in their final position when the connections are made. Appropriate allowances for lack of fit must therefore be incorporated; for example, the connections between secondary beams and a pre-cambered primary beam should allow for the fact that the beams will not all lie in one plane under the self weight of the steel alone. Similarly, the tips of a row of cantilevers connected to different supports will vary in position depending on the degree of fixity provided by the connection. If a constant level is needed for aesthetic reasons, or to allow attachment of cladding, the designer must make provision for this when detailing the connections or cladding supports.

Frame movement must also be allowed for when the position of a part erected structure is checked on site. For example, it may be appropriate to pre-set the legs of a portal frame so that they lean in under self weight alone. Verticality will be achieved as loads are increased. The amount of pre-set is difficult to assess, since accurate prediction of deflections in general is not possible due to problems of accurately calculating base fixity, connection rigidity etc. This problem also affects the pre-cambering of beams, since the amount of pre-camber required to reduce final deflections cannot be accurately calculated.

For heavy steelwork, lining and levelling should be complete to within two bays of the erection front to avoid instability due to incomplete connections. For light steelwork this can be increased to four bays. In the case of a frame with rigid connections, it is time consuming to make any further adjustments after the joints have been fully bolted, and impossible if the joints are welded.

If appropriate, the survey results should be corrected for the effects of temperature; in most cases when surveys take place between 5°C and 15°C and no correction is necessary according to ENV 1090-1⁽⁸⁸⁾.

KEY POINTS - General principles of site practice

Site practice needs to be appreciated by the designer wishing to *design for construction*. The following points summarise those aspects that are of most relevance to him.

- The steelwork contractor's erection sequence must meet main contractor's requirements.
- The steelwork contractor's erection sequence must maintain stability at all times.
- All parties, including the designer, should be realistic about the as-built frame position.

4.2 Erection equipment and techniques

4.2.1 Cranage

Cranes may be divided into two broad categories, mobile and non-mobile. The first category includes truck mounted cranes, crawler cranes and all-terrain cranes, whilst the second category primarily covers tower cranes.

Mobile cranes

Normally, truck mounted cranes do not require a back-up crane for site assembly, and require very little set-up time. These two attributes mean that they are suitable for one-off, single day commissions. Because of their popularity they are readily available from plant hire companies throughout the UK, who quote competitive rates and generally have alternative cranes available.

The main drawback with truck mounted cranes is that to achieve a high lifting capacity from a light vehicle, a larger footprint is required than for an equivalent crawler crane. The size of the footprint can be increased using outriggers, but good ground conditions are necessary to provide a solid base and ensure adequate stability. It is important to remember that ground conditions at the time of erecting the steel frame may not be the same as the 'green field' conditions. This problem may be eliminated if, as occasionally happens, the ground slab of a building is designed to allow for crane access.

Crawler cranes are more rugged than truck mounted cranes. Ground conditions are therefore less critical. Crawler cranes may travel with suspended loads on site, because they are stable without the use of outriggers. They also have a relatively high lifting capacity. Daily hire is not possible for crawler cranes, because transportation to and from site is expensive, and they require site assembly. They are however more competitive than truck mounted cranes for long periods on site in a relatively fixed location. The minimum hire period is generally one week.

All-terrain cranes provide a compromise between the advantages and disadvantages of crawler cranes and truck mounted cranes. They are about 20% more expensive to hire than the latter.

Typical mobile cranes, be they crawlers, truck mounted cranes, or all-terrain, have a rated capacity of around 30 t to 50 t. The largest examples are rated at over 1000 t. However, actual lifting capacity is a function of radius, and may be much less than the rated capacity for a given situation (see examples below). 'Heavy-lift' rigs can be used to increase the capacity of large cranes for one-off applications.

Tower cranes

Tower cranes must be assembled on site, because of their size, and this operation often requires a second (usually truck mounted) crane. Set-up, and similarly dismantling, are therefore expensive. They also have a relatively slow lifting rate, which means they are only used when site conditions preclude an alternative. A further consideration when specifying a crane is that tower cranes are 'vulnerable' to wind loading, which may prevent crane use at times. Their advantages are an ability to lift to greater heights than a mobile, and to lift their rated capacity over a significant proportion of their radius range. Crane geometry means that a tower crane can be erected close to, or within, the building frame. A tower crane may even be tied to the building frame to provide stability as height increases. Alternatively, climbing cranes may be used. These are supported off the steel

frame itself. Some mobility can be achieved by running a tower crane on tracks. In this way it may be possible to pick up pieces from a stockyard, travel across the site, and erect them directly. Several types of tower crane are in current use; saddle jib, luffing jib and articulated jib. Reference should be made to specialist literature for more information.

Choice of crane

The choice and positioning of a crane or cranes is influenced by many factors. The principal items to be considered are:

- site location - access and adjacent features
- duration of construction
- the lightest and heaviest pieces to be erected, and their position relative to potential crane standing positions
- size of pieces to be erected
- the need for tandem lifts
- maximum height of lift
- number of pieces to be erected per week (remembering that a tower crane on a congested site will not normally be dedicated to steelwork erection alone)
- ground conditions
- the need to travel with loads
- the need for cranes to be spread over a number of locations
- organisation of off-loading and stockyard areas
- dismantling.

In practice crane choice will be a compromise. If no practical solution can be found, then the designer may need to consider reducing member weights, bulk etc. Further guidance on crane selection is available in Reference 27.

KEY POINTS - Cranage

Four basic types of crane are used on site. They have the following principal characteristics.

Truck mounted cranes: flexible, readily available

Crawler cranes: stable, rugged

All-terrain cranes: compromise

Tower cranes: high lifts, useful radius

The following three examples give an indication of the capabilities and costs of different crane types.

Example 1 - Tadano TL-300E truck mounted crane

The rated capacity is 30 t. This magnitude of load can be lifted at a radius of approximately 3 m, where the maximum lifting height is approximately 50 m. The variation in lifting capacity with radius is given in Table 4.4. The product of the capacity and radius reduces by a factor of six as the radius increases from 3 m to 30 m. Hire rates were approximately £250 per day in 1996, for a minimum of one day. A smaller truck mounted crane (20 t) costs approximately £170 per day, whilst an 80 t crane costs approximately £600.

Table 4.4 *Lifting capacity of Tadano TL-300E*

Capacity* (t)	Radius (m)	Max. Height (m)
30	3	50
5.7 - 7.3	10	47
1.6 - 2.2	20	44
0.5	30	35

* capacity varies according to outrigger arrangement

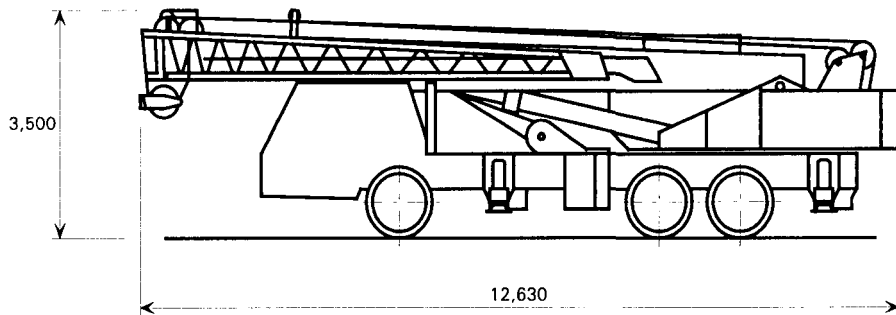

Figure 4.4 *Tadano TL-300E truck mounted crane*

Example 2 - NCK - Rapier Andes C41B crawler

The rated capacity is 40 t. This magnitude of load can be lifted at a radius of approximately 4 m. The maximum lifting height is approximately 44 m at this radius. The variation in lifting capacity with radius is given in Table 4.5. Hire rates in 1996 were approximately £950 per week (daily hire is not possible because of the time needed to set-up/dismantle the crane).

Table 4.5 *Lifting capacity of NCK-Rapier Andes C41B*

Capacity* (t)	Radius (m)	Max. Height (m)
37 - 41	4	44
9.1 - 10.6	10	43
3.0 - 4.5	20	40
1.2 - 1.6	30	33

* capacity varies according to boom length

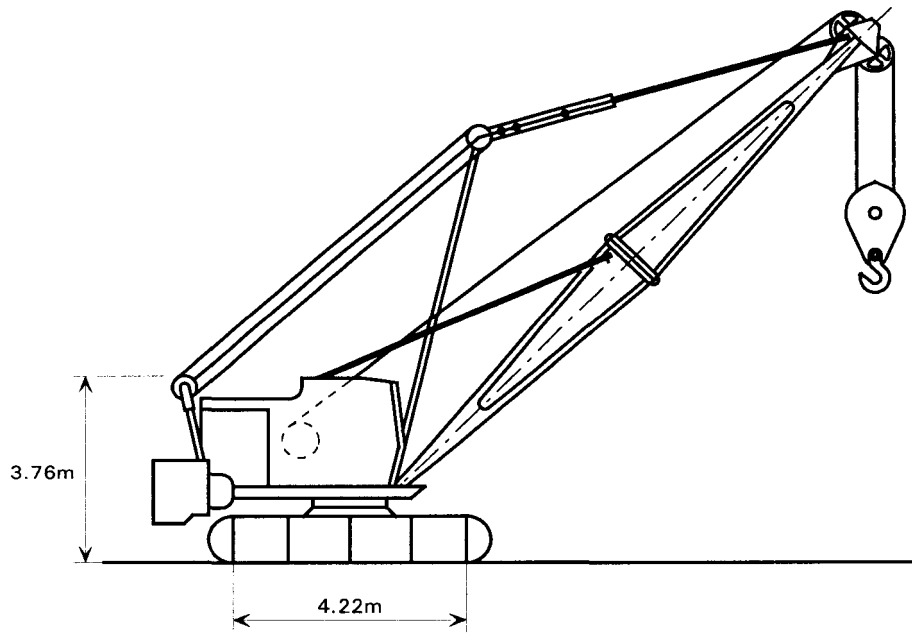

Figure 4.5 NCK - Rapier Andes C41B crawler crane

Example 3 - Peiner SK206/1 tower crane

The rated capacity of 12.5 t can be lifted at a minimum radius of approximately 3 m. Maximum lifting height is 59.9 m, independent of radius. The variation in lifting capacity with radius is given in Table 4.6; the capacity is constant within a 10 m radius. Hire rates were approximately £1450 per week in 1996.

Table 4.6 Lifting capacity of Peiner SK206/1

Capacity* (t)	Radius (m)	Max. Height (m)
12.5	3	59.9
12.5	10	59.9
9.2 - 11.9	20	59.9
5.7 - 7.5	30	59.9

* capacity depends on the jib arrangement

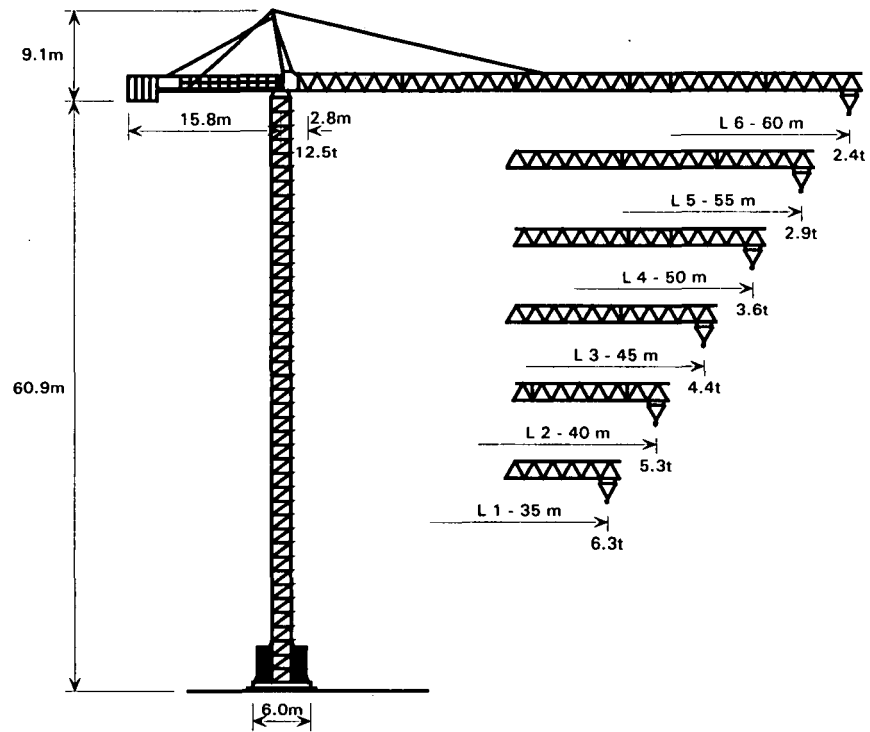

Figure 4.6 Peiner SK206/1 tower crane

4.2.2 Lifting equipment and techniques

To ensure safe lifting, appropriate equipment must always be employed. A range of special lifting equipment, which compliments the basic items often preferred by erectors, is available for use with cranes. Examples of special equipment include:

Remote release shackles (Dawson ratchets, see Figure 4.7) : can be used to lift columns into position and avoid chains biting into paintwork or intumescent coatings.

Nylon slings : may be used to reduce damage to coatings, but they should not be used in wet weather (insufficient grip).

Sleeved chains : may also be used to avoid damage, but in practice without some biting in it is difficult to obtain sufficient grip.

Lifting beams : are used for large, slender items. These distribute the weight and effectively stiffen and strengthen the member to prevent damage during erection.

When lifting brackets are provided, they should be properly planned for so the member or sub-frame can support the concentrated loads, If brackets are not used, but lifting positions are critical, then lifting points should be clearly marked on the member or sub-frame (see Figure 4.8).

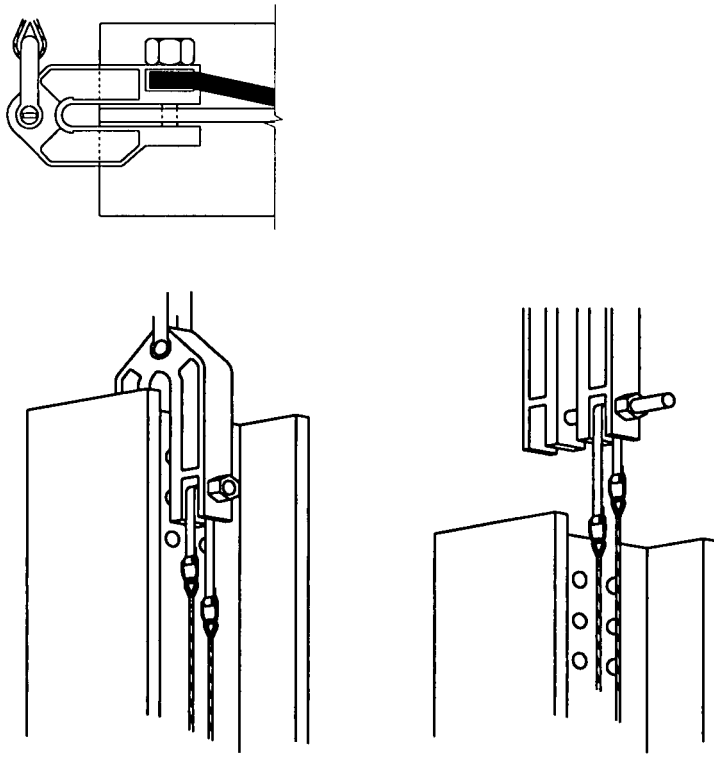
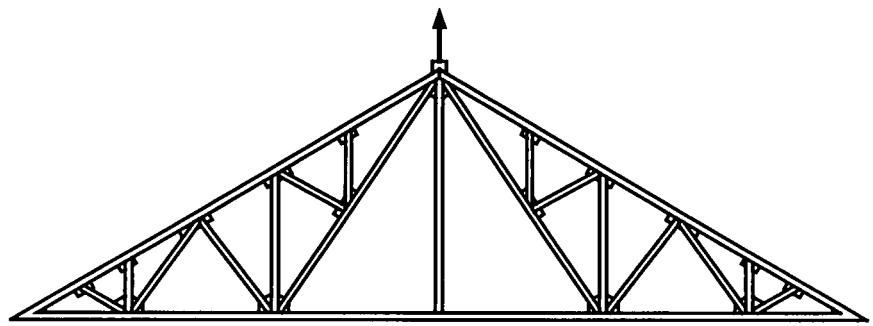
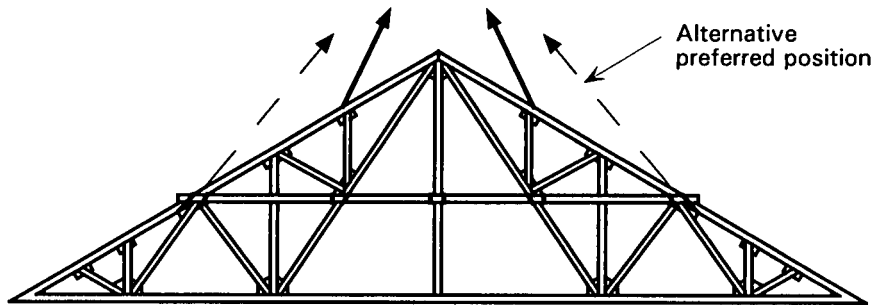

Figure 4.7 *Dawson ratchet*



Incorrect - Bottom boom in compression and liable to buckle



Correct - Strong back or stiffener used to prevent damage

Figure 4.8 *Lifting of a truss*

Tandem /lifting

Tandem lifting can be used if the weight or, more often, size of a load is such that it cannot be safely handled by a single crane. For example, if the truss shown in Figure 4.8 was sufficiently long that a single crane could not pick up the required attachment points, it would be necessary to perform a tandem lift using two cranes. More than two cranes may sometimes be required.

The whole operation must be carefully planned by the steelwork contractor, and carried out under proper supervision. It should not be assumed that the weight will be shared equally between the cranes, since manipulation of the load into position may alter the weight distribution. The cranes used must have similar characteristics, and the safe working load of each crane should normally be at least 25% in excess of the calculated shared load.

4.2.3 Pre-assembly on the ground

Pre-assembly on the ground may be adopted for the reasons already stated at the beginning of Section 4. However, before specifying the use of pre-assembled units, the designer should consider the following four factors. These factors affect the economy and practicality of using such a method:

- the weight of the sub-frame (including any lifting beams)
- the degree to which it is capable of being temporarily stiffened within weight constraints
- its bulk
- the need to use a crane to handle it.

When sub-frames are used, provision must be made to ensure that sufficient space is available on the ground. Pre-assembling may take place either in a suitable clear area, if the load can be moved easily, or behind the crane at the erection front. The most common components to be assembled on site are roof trusses and lattice girders.

4.2.4 Temporary bracing

When a 'stiff box' cannot be achieved early in the erection process by the provision of permanent frame members (see Section 3.2), temporary bracing is needed. A particular example is when the permanent bracing system relies on a component which is not in position during erection of the steel frame (for example a concrete shear wall).

The temporary works designer will need to consider the following points when designing the temporary bracing:

- the stiffnesses of the temporary bracing members, which may differ considerably from those of the permanent frame members. For example, wire ties have considerably less axial stiffness than rolled members, and whilst this is generally unimportant, situations can be envisaged where the frame movement permitted by flexible bracing would be unwelcome.
- load paths through permanent members which are used as part of the temporary bracing system. For example, a beam which has only been designed for bending and vertical shear in the final state may be subject to considerable axial load.
- the action of wind on the bare or partially clad steel frame. Very large horizontal loads can be developed in this state, although generally design to

resist wind loads on the final clad structure is more likely to govern the temporary bracing.

- the stage at which the temporary bracing can be removed (and who will be responsible for its removal).

It will generally be found that the strength of temporary bracing is likely to be more critical than its stiffness. Temporary bracing may also be used:

- to support unstable columns prior to erection of the beams
- to laterally restrain compression members before the floors or roof are in place
- to support continuous beams prior to the completion of splices
- when sliding or rotating supports are used.

KEY POINTS - Erection equipment and techniques

- Different types of crane are suited to different situations. The building design should consider the type of crane which can be used.
- The designer should be aware of the different lifting equipment and techniques which are available.
- Particular attention must be paid to temporary bracing design, to ensure that stability is maintained at all times.

4.3 Case study - Senator House

Senator House is a sophisticated eight storey office building which was built in London in 1990, comprising a 13400 m² main building and a 1200 m² annexe. In addition to the client's requirements for maximum lettable floor area and a minimum number of internal columns, the location placed an overall restriction on building height. The 3.55 m floor to floor spacing which was made possible by the framing system is extremely low compared with normal UK standards.

Management of the project had to cope with a complex interaction of several parties. Responsibilities for the tasks within the steelwork package are shown in Figure 4.9. Careful planning and good communications were two of the keys to success. The result was a lead-in time of only six weeks, and erection, including fixing of the steel decking, in 15 weeks.

The frame was split into 24 two-storey-high zones for erection. The size of each zone was chosen to represent 10 days work for a team of seven men. This gave the team a volume of work on a 'human scale', so they could focus their efforts more effectively. Figure 4.10 shows a plan of the building indicating the six principal zones (A to F), each of which contained four zones to achieve the full eight storey height. Although two tower cranes are indicated in this plan, generally only one was used at any one time for erection of the steelwork.

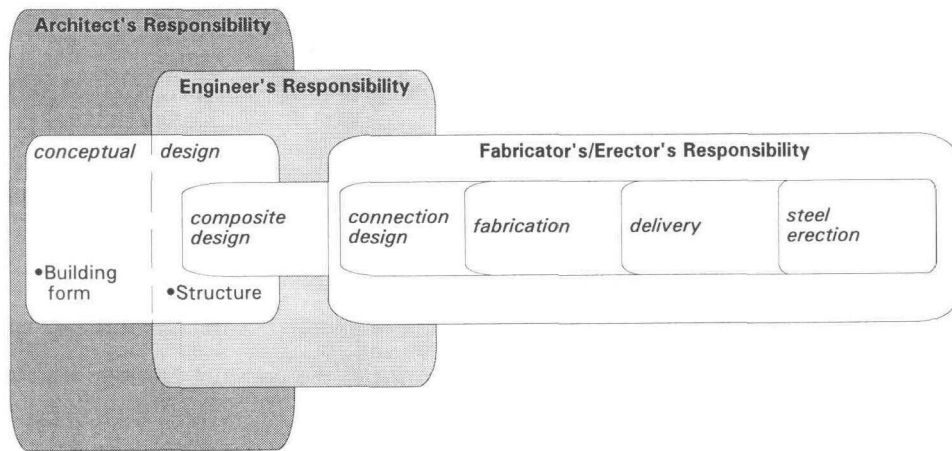

Figure 4.9 Responsibilities for processes within the steelwork package, Senator House

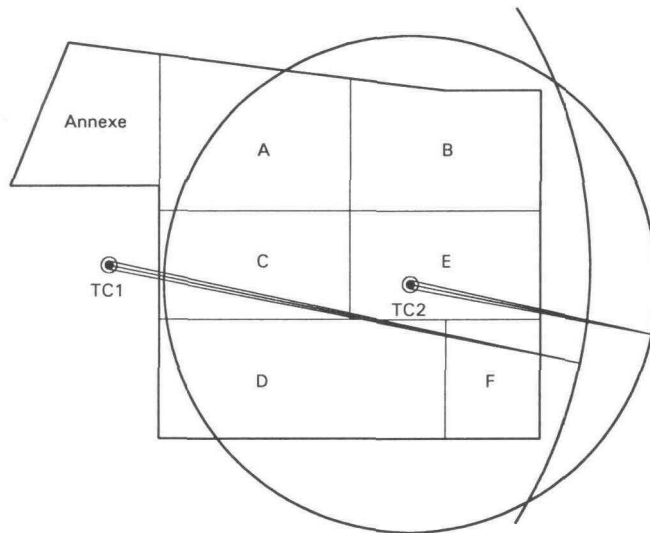

Figure 4.10 Plan of Senator House showing work zones

One team was responsible for all the work within a particular zone, rather than adopting the traditional division of erection and bolting up teams. The emphasis on a single team objective, to achieve completion of one zone through collective responsibility, was a significant feature of the organisation of the site work. To ensure that the crane was as busy lifting as possible, one team would work on bolting up their zone while the second team was erecting an adjacent zone.

The sequence of erection used was basically as given in Section 4.1.4. A peak rate of 60 pieces per crane hook per 10 hour shift was achieved, with an average of 39 pieces. Historically, the average was 25 pieces per hook per shift⁽²⁸⁾. This is an important performance indicator, because build time is heavily influenced by the number of members lifted into position in a given period, i.e. by how 'efficiently' the crane is used. The number of pieces lifted per hour was maximised at Senator House by minimising the time spent slewing and hoisting.

Site meetings were held weekly between steelwork erection teams, project manager and director to discuss safety, the week's work programme and any problems.

Before each shift there was a meeting with each team to lay out the plan for the day and sort out any likely problems. A fabricator's representative visited the site daily to ensure good communication with the erectors.

The main contractor took a very positive leadership role in the management of the steelwork package, being concerned to know where every aspect of the process was at any time, and requiring full and honest reporting of progress. The steelwork contractors responded and raised their own levels of cooperation and coordination accordingly. Although this intensive management required considerable resources, and was therefore relatively expensive, it was cost effective in terms of the overall project.

The information given to the erection teams was simplified. Each piece of steel had a unique reference code related to section, level and piece number. An A3 drawing was prepared for each section showing the piece codes and location. Bolt requirements were shown adjacent to each section. In this way a single document served for erection, bolting and alignment, as well as quality control.

KEY POINTS - Senator House

Design criteria:

- Restricted height
- Minimum internal columns
- Grouped into work zones

Characteristics:

- Braced
- 6m UB primary beams
- 12m composite stub girder secondary beams

Performance:

- 6 weeks lead-in
- 72 t fabricated per week
- 15 weeks erection
- Average 39 pieces/hook/shift
- Peak 60 pieces/hook/shift
- 101 t erected per week
- 195 pieces per week
- 1231 m² of floor area per week

4.4 Further reading

(For further information, see Section 9, References)

Structural steelwork - erection⁽²⁹⁾ Written primarily in order to give undergraduates and young engineers and managers entering the construction industry an introduction to the world of construction, and steel erection in particular. Covers erection techniques, site safety, plant and equipment used.

Erector's manual⁽³⁰⁾ A pocket sized book which gives guidance on safe and efficient site procedures, amongst many other things. Detailed information is given for supervisors, charge hands, erectors, etc. Written and presented in a form to serve as a frequent reference on site.

Steel designers' manual⁽³¹⁾. Extensive contents includes 44 pages in Chapter 33 covering erection. Subjects covered include method statements, programmes, cranes, the use of sub-assemblies, safety, site practice and special structures.

The National Structural Steelwork Specification for Building Construction, 3rd edition⁽⁶⁾. Presents workmanship requirements for the accuracy of erected steelwork. These are reproduced in Section 8 of this document. See also Further Reading in Section 2.4.

Commentary on the third edition of the national steelwork specification for Building Construction⁽¹⁰⁾. The title of this book is self-explanatory.

Construction led⁽¹³⁾. Series of articles published in *Steel Construction Today* and *New Steel Construction in 1993*. See also Further Reading in Section 2.4.

Steelwork erection (guidance for designers)⁽³²⁾. An eight page booklet giving a qualitative introduction to issues associated with the erection of steelwork.

Crane stability on site⁽³³⁾. The purpose of this guide is to bring together the main points which need to be considered to ensure that a crane remains stable at all times. Its main focus is stability in use. Includes check lists and case studies.

A systematic approach to the selection of an appropriate crane for a construction site⁽²⁷⁾. This paper presents a systematic approach for selecting a suitable crane, based on the experience and knowledge of experts.

Selection of cranes⁽³⁴⁾. A two page article which discusses various crane types and on-site criteria for crane selection.

Where hire '96⁽³⁵⁾. A contractors' guide to plant and tool hire companies throughout the U.K.

New steel work way - the way ahead for the U.K. steel construction industry⁽³⁶⁾. Highlights differences between Japanese and U.K. practice, including erection techniques and equipment.

Design guide for wind loads on unclad framed building structures during construction. Supplement 3 to the designer's guide to wind loading of building structures⁽³⁷⁾. During construction there is little self weight to counteract uplift, and the guide provides a quick and realistic assessment of wind forces in these conditions. It supports CP3: Chapter V: Part 2 (which is being superseded).

A case study of the steel frame erection at Senator House, London⁽²⁸⁾ . A 24 page book which gives a detailed account and photographic record of this project.

Lack of fit in steel structures⁽³⁸⁾ . Considers lack of fit in different types of connections, and its effect on overall frame stability and corrosion. Avoidance of fit problems is also considered.

Lateral movement of heavy loads⁽³⁹⁾ . Provides an introduction to techniques which may be used on site for moving very large loads laterally.

5 HEALTH AND SAFETY - THE CDM REGULATIONS

5.1 The Regulations

The Construction (Design and Management) Regulations 1994 (CDM) place significant responsibilities on the designer, recognising the importance of his role during the early stages of a project⁽²⁾. Because of his input during the concept and scheme design stages, he can arguably have a greater influence than anyone else on issues of buildability and safety. To ensure that this influence is positive, the designer must carefully think through:

- how the structure will be built
- how it will be used.

5.2 Duties under CDM

The CDM regulations came into force on the 31st March 1995, and were published with an associated Approved Code of Practice (ACoP)⁽⁴⁰⁾. Their particular relevance to the designer of steel structures is outlined in *The Construction (Design and Management) Regulations 1994: interim advice for designers in steel*⁽⁴¹⁾. The primary thrust of the regulations is to ensure that structures can be both constructed and used safely. Note that *use* in this context includes operations such as maintenance, re-decoration, repair, cleaning and demolition.

The definition of *designer* adopted in the regulations is broad, and includes architects, quantity surveyors and contractors, in addition to structural engineers. Also, the regulations do not cover what is commonly thought of as *design*, namely checking the structural adequacy of the frame, members or connections. They concern the manner and method of construction, maintenance etc., and are therefore of major importance during the concept and scheme design stages.

The regulations place new responsibilities on clients, designers, planning supervisors and contractors. These responsibilities are listed in Reference 41. The responsibilities of the designer are reproduced below. The regulations also enforce the creation of two important documents, the *Health and Safety File* and the *Health and Safety Plan*. It is the responsibility of the planning supervisor to ensure that these are created, but the designer makes a significant contribution to both. Their contents are discussed in Section 5.3.3.

It must be emphasized that the CDM regulations do not mean that safety issues dominate design at all cost. They should be considered alongside other design criteria such as cost and aesthetics.

5.3 Designer's responsibilities

The following four points outline the designer's responsibilities:

- make the client aware of his responsibilities
- give due regard to health and safety issues, so that risks can be avoided, reduced or controlled
- provide information which a contractor, although competent, would not necessarily know
- co-operate with the Planning Supervisor and other designers.

It is strongly recommended that the designer documents his actions, and decisions made. The planning supervisor is required to ensure that the designer has fulfilled his obligations, and the designer may therefore be audited in case of an enquiry.

Particular responsibilities of the designer with regard to 'risk', and some of the actions he must take to fulfil his obligations, are considered in the Sections that follow.

5.3.1 Foreseeable risks

The principal action the designer must take is to give adequate regard to *foreseeable risks*. Although the terms *risk* and *hazard* are both used in the regulations, for the purposes of simplicity, they are grouped together under the general term *risk* in these guidelines. The important thing to note is that risk is taken as having a sense of both frequency of occurrence and severity of outcome.

The meaning of *foreseeable* is important. The designer cannot prevent unsafe practices on site, where the contractor remains responsible for health and safety. These are not therefore foreseeable as far as the designer is concerned. Furthermore, foreseeable risks are only those which fall within 'state-of-the-art' understanding at the time the design is prepared.

Two mechanisms are adopted in the regulations to ensure that the designer gives adequate regard to foreseeable risks:

- the client may only employ a *competent* designer,
- the planning supervisor must ensure that the designer fulfils his obligations.

Considering the first of these, the following general criteria must be satisfied for a designer to be deemed competent (more detailed information is given in Reference 40). He must possess, and be able to demonstrate:

- an understanding of the work involved
- an awareness of relevant current best practice (as presented in British Standards, design guides etc.), and an ability to apply it to the project
- awareness of the limits of his experience and knowledge (which need only extend to the requirements of the project in question, bearing in mind that these commodities generally cost money).

Traditionally, many designers have not concerned themselves with how a structure is to be built. This was left entirely to the contractor, an attitude which is no longer permitted. The ACoP notes that 'as the design develops, the designer needs to

examine methods by which the structure might be built, and analyse the hazards and risks associated with these methods in the context of his design choices’.

Even less attention has traditionally been paid to the use, maintenance, repair and demolition of a structure. Consideration of the risks arising from these activities now forms one of the designer’s obligations.

The designer also has significant influence in the specification of components. Note that specification falls within the definition of design, according to the regulations. The regulations require that the selection of materials, equipment etc. is given similar attention to that of the construction method itself.

5.3.2 Risk assessment

Having identified the risks associated with a project, risk assessments must be carried out so that their relative importance can be established and appropriate actions identified. A plethora of systems is available to assist the designer in risk assessment. The Health and Safety Commission⁽⁴⁰⁾ illustrates a simple example, based on a subjective assessment of the likely severity of harm, combined with the likelihood that harm will occur. This example is represented in Table 5.1. A ‘severe’, ‘frequent’ risk should prompt serious consideration of design changes.

Table 5.1 *Categories of likely severity and likelihood of occurrence of risks*

	Likely severity	Likelihood of occurrence
High	fatality, major injury, long-term disability	certain or near certain to occur
Medium	injury or illness causing short-term disability	reasonably likely to occur
Low	other injury or illness	rarely or never occurs

5.3.3 Avoid, reduce, protect, inform

Having identified risks, and where appropriate demonstrated by means of a risk assessment their importance, the designer should follow the hierarchy given below when dealing with them:

- avoid the risk
- reduce the risk by combatting it at source
- protect people (workers and public) from the risk
- inform others of a risk which will need to be controlled.

To illustrate this hierarchy consider the example of plant which is to be located on the roof of a building. Certain risks are associated with installing and maintaining this plant. The first option for the designer is to consider whether the risks can be avoided, namely by locating the plant at a lower level. If this cannot be done, he should consider reducing the risks, for example by using low maintenance plant which will reduce the frequency of operations at roof level. If neither of these two options is feasible, he must consider protecting from danger the men who will install and maintain the plant. He could do this by providing suitable access (walkways and handrails). For this example it is difficult to imagine that the

designer could not at least do something to provide protection, even if he were unable to avoid or reduce the risk. However, if this was not possible the least the designer would have to do would be to inform the client of the need to control the risks associated with plant installation and maintenance (for example by stating in the Health and Safety File (see below) that special measures will need to be taken during plant maintenance).

Health and Safety Plan

Within the context of informing others, it may be desirable to provide certain information on health and safety issues in the contract drawings, bills of quantities etc. The regulations also require the preparation of a *Health and Safety Plan*, containing:

- a general description of the work
- details of the proposed programme for the work
- details of the risks to be encountered during construction
- information so the contractor may allocate sufficient resource to the control of construction risks
- information which it would be reasonable for a contractor to know in order to comply with any statutory provisions or in respect of welfare.

Health and Safety File

The second repository for information required by the regulations is the *Health and Safety File*. The purpose of this file is to assist persons carrying out maintenance or construction work on the structure at any time after completion of the initial construction (for example modification, demolition). The ACoP suggests that the file may include:

- ‘as built’ drawings
- details of the construction methods and materials used
- details of equipment and maintenance facilities
- maintenance requirements and procedures
- details of the location and nature of utilities and services, including emergency and fire fighting systems.

5.4 Designer’s response

Many hazards exist, the majority of which are independent of the construction material⁽⁴¹⁾. However, the structural designer’s response to some common, generic hazards are considered in detail in the Sections that follow.

5.4.1 Frame/member instability

The frame or certain members may be unstable in the temporary state. Typical examples of this include:

- a frame which relies on other permanent works (for example concrete elements) for stability. Often these other works are not complete at the time when the frame is to be erected
- rafters which have no restraint until the permanent roof decking is fixed.

In these instances the designer must at least inform those who may be affected that the problem will occur, and that it must be controlled during construction. He should also indicate how he assumed the problem would be tackled. The contractor may need to provide temporary works (see also Section 4.2.4) to support the frame or members during erection, such as:

- wire pullers (Tirfors)
- push-pull props
- scaffolding
- military trestles
- job specific items (temporary bracing, fabricated trestles).

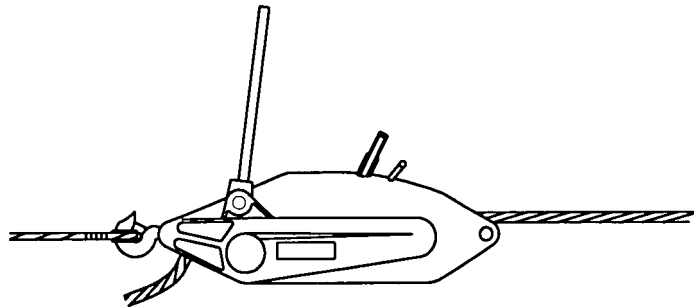

Figure 5.1 *Tirfor wire puller*

5.4.2 Working at height

Although working at height is undoubtedly hazardous, it must not be forgotten that steel erectors are experienced specialists. The regulations only permit the appointment of competent contractors.

The designer must consider if there are any features of the design which are unusual, or unduly onerous for erection at height. Features falling in this category may include items which are difficult to handle and locate, or connections which are difficult to access. Similarly, it may be possible to omit some work at height altogether, for example sag bars between purlins are not always necessary, depending on the choice of purlin section.

Prefabrication may be used in order to reduce the time spent working at height. However, a prefabricated unit may be more difficult to handle, particularly on site. Storage and lifting of bulky items should be considered. Items which are significantly heavier than the average piece weight may have an onerous effect on the crane requirements in terms of speed and cost. The provision of properly designed lifting points should be considered for unorthodox or unwieldy items (see Section 4.2.2).

A number of options are available to reduce the risk to erectors working at height including:

- the provision of holes for girder grip ('man lock') safety devices
- the erection of steelwork using remote release shackles
- the provision of seating arrangements for positive location of major components
- erection of items with hooks, walkways, ladders or safety wires already attached

- provision for temporary access platforms
- access from man riding cages, or from mobile elevated working platforms (MEWPs, commonly called ‘cherry pickers’ or ‘scissor lifts’).

Prefabricated stairs, when programmed for early installation, provide safe access to the frame for following trades.

5.4.3 Site cutting / welding

Site cutting and welding involve a number of hazards, including gas, electricity, sparks, noise, the welding arc and debris. However, the risks must be weighed against the engineering and other advantages of site cutting and welding. These operations can be carried out safely. Ways to reduce the risk and to protect include:

- prefabrication
- the provision of access platforms
- protection from the elements
- protection of others
- personal protection of the operatives.

5.4.4 Harmful substances

Potentially harmful substances include certain paints, fire protection and grouts. Safer alternative products may be specified, or in some cases the treatment can be applied off-site under more controlled conditions. To reduce the risk, less hazardous methods of application may be chosen, such as brush applied paint systems instead of sprayed systems. Measures to protect may include personal protection for the operative, and exclusion of other staff. Adoption of alternative systems must recognise the potential effect on the construction programme.

ACTIONS - Health and safety - CDM

Safety concerns all parties involved in a construction project. The principal actions to be undertaken by a designer are listed below.

- Make the client aware of his responsibilities.
- Give due regard to health and safety issues, so that risks can be avoided, reduced or controlled.
- Provide information which a competent contractor would not necessarily know.
- Co-operate with the Planning Supervisor and other designers.

5.5 Further reading

The Construction (Design and Management) Regulations, 1994. Advice for designers in steel(41). Describes the responsibilities of the principal parties involved in a project, with a particular focus on the designer. The document describes how the designer can fulfil his obligations, with comments on typical hazards specific to structural steelwork.

Guidance note GS 28: Safe erection of structures(42). This important document, produced by the Health and Safety Executive, should be considered as essential reading. It is in four parts:

- Part 1: Initial planning and design
- Part 2: Site management and procedures
- Part 3: Working places and access
- Part 4: Legislation and training

Opportunities and impositions(43). This publication contains a realistic examination of the practical impact of the Regulations.

The CDM regulations explained(44). This is a definitive guide to the regulations, without reference to particular construction sectors.

CDM regulations - case study guidance for designers(45). An interim report produced by CIRIA, this publication contains a number of hypothetical case studies. It was prepared shortly after publication of the regulations.

CITB construction site safety - safety notes(46). Covers a broad range of site safety issues, including the use of specific items of plant and tools. Identifies current safety regulations.

Managing Construction for Health and Safety - Construction (Design and Management) Regulations 1994. Approved Code of Practice(40). This document contains the regulations themselves, together with an explanatory commentary for each rule.

Designing for health and safety in construction(47). This publication includes helpful guidance on how the designer can fulfil his obligations, with suggestions on the form of risk assessments.

6 INTERFACES WITH STRUCTURAL COMPONENTS

Getting the interfaces 'right' is essential when designing for construction. To reflect this importance, Sections 6 and 7 give considerable detail concerning various interfaces. The information given covers all aspects associated with the chosen interfaces, covering both design and construction issues.

6.1 Foundations

To facilitate alignment of the erected structure, the method of attaching the steelwork to the foundations must provide a means of adjusting line and level. The most common way to attach a column to the foundations is by holding-down bolts cast into the base, using sleeves to form a void around each bolt and permit movement of the bolt tip following concreting. If possible the same holding-down detail should be used for all columns. Bolt groups set-out on a uniform grid reduce the likelihood of errors during positioning by the main contractor. A typical system is shown in Figure 6.1.

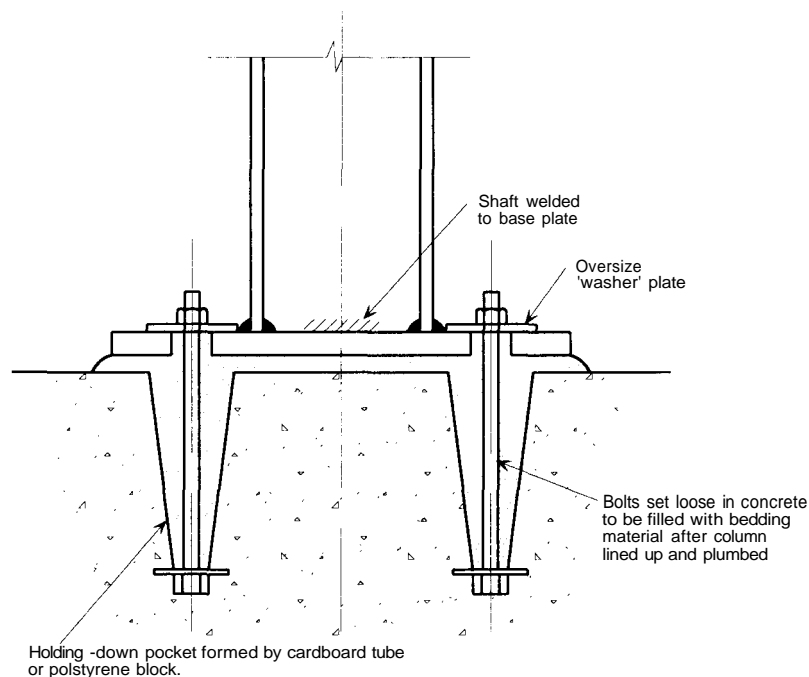

Figure 6.1 *Typical holding-down arrangement for a nominally pinned base*

Even if the base is designed as nominally pinned, four bolts should be used, to improve stability of the column during erection and to facilitate plumbing-up. A by-product of this is that, even though nominally pinned, the base transfers some moment to the foundations. The bolts are best located near the perimeter of the baseplate. This makes tightening-up easier, and avoids a congested area near the middle of the plate which would inhibit flow of the bedding material into this

critical region. The bolts and baseplate may be cast into a screed to keep them below the finished floor level.

Before deciding to use moment resisting connections at column bases, the designer should carefully consider whether they are necessary for the frame design (for example, they are often needed for ‘crane buildings’, and tall unbraced buildings). Increased foundation complexity, and therefore increased total cost, is the main consequence of adopting moment resisting bases. When nominally pinned bases are chosen, the holding-down bolt size is normally determined by the moment needed to stabilise the column during erection (although other load conditions should also be considered).

6.1.1 Cast-in bolts

One of the benefits of using sleeved cast-in bolts is that, theoretically at least, the positions of the bolt tips can be adjusted following concreting of the base slab. To facilitate this the bolt sleeves must be of sufficient diameter, and may be conical, as shown in Figure 6.1.

Conical sleeves maximise possible movement at the bolt tip without reducing the area of concrete which provides anchorage. The diameter of the top of the sleeve should be approximately three times that of the bolt. Moving each bolt in its sleeve as the concrete is curing is essential to ensure that the potential adjustment offered by the use of sleeves is not lost.

Several problems can arise in practice when using sleeved bolts, and these may affect the ability of the erector to correctly locate the columns:

- Accurate positioning of bolt groups requires care. A wooden template should be used to align the bolt tips. Complicated steelwork used to anchor the bolts may be difficult to position correctly amongst reinforcing bars. Because the contractor responsible for the foundations has no further direct involvement in the erection of the steel frame once the base is poured, the necessary care is often not taken.
- Accurately set-out bolts require care to maintain them in the correct position during concreting.
- Correctly positioned bolts may be bent or damaged after the concreting operation. The practice of heating and bending bolts to bring them back into the desired position should be avoided, since the properties of the steel used for high strength bolts may be adversely affected by the application of heat. To reduce the likelihood of projecting bolts being damaged, a diameter of less than 20 mm should not be used. Threads should be protected against damage.
- In addition to correct alignment, there is a need for a minimum projection of the bolts above the base. The NSSS⁽⁶⁾ requires that the level of the base should be within a tolerance of +0 to -30 mm, and the level of the top of the bolt should be within the range +25 mm to -5 mm in order to ensure the necessary projection. If the bolt projection is insufficient, then remedial measures may be required, such as fitting a sleeve over the short bolt and enlarging the hole in the baseplate so that the column can be located over this sleeve. Welding on an extension when bolts are too low should be avoided because of the change in properties of the steel which may take place during heating.

When bolt positions are outside specified tolerances, remedial measures will inevitably involve adapting the column bases. Oversizing the holes in the baseplate, extending the baseplate, or using post fixed anchors may need to be considered.

KEY POINTS - Cast-in bolts

The use of cast-in bolts should give sufficient adjustment on site at the interface between the foundations and the steel frame. However, site work must ensure that:

- bolts are properly located in the specified positions prior to concreting
- bolts are not displaced during concreting
- bolt tips are not damaged following concreting
- bolts project a sufficient distance above the top of concrete
- bolts are free to move within their sleeves.

6.1.2 Bedding material

Having located a column and adjusted its line, level and plumb using the procedures outlined in Section 3.1.6, bedding material must be placed beneath the baseplate. Several different types of bedding material can be used depending on the size of the gap under the plate.

For orthodox bases with a typical 25 mm to 50 mm gap, by far the most common material is non-shrink cementitious grout. This is pre-bagged so that it only requires the addition of water to achieve reliable final properties of the grout. A method statement for placing the grout should be prepared to ensure that the bolt sleeves and void under the baseplate are filled to the expected standard.

Good access aids cleaning out of the sleeves before locating the column, and subsequent placing of the grout. Locating the column base in a recess in the base slab may severely restrict access, although it does provide a good shear key and may be an efficient way of keeping the baseplate detail below finished floor level. Holes should be provided in larger baseplates (more than 700 mm X 700 mm) to allow trapped air to escape, and facilitate placement or inspection of the grout. One hole should be provided for every 0.5 m² of plate⁽¹⁵⁾. If the holes are to be used for placing the bedding material, they should be 100 mm in diameter, otherwise they need only be 50 mm. Packs placed under the baseplate for levelling of the column during erection can be left in place⁽⁶⁾, provided this is agreed with the client's representative.

In addition to an increased likelihood of bolt corrosion, a consequence of poor filling of the sleeves may be an inability of the bolts to transfer horizontal loads into the foundations. However, often this is not a problem because friction between the baseplate and grout (under high axial load) is sufficient to resist horizontal loads. No special provisions are required if the shear loads are less than 20% of the axial load⁽¹⁴⁾. When this is not the case, the bolts are generally designed to resist the shear loads and sound placement of the bedding material is essential. Alternative

details may be used to resist horizontal loads. A shear key might be welded to the underside of the baseplate, although this could interfere with the positioning of the column and impede the flow of grout under the plate. Alternatively, the column could be anchored to the base slab using a tie. The practice of running a tie across the full width of the frame to join the legs of a portal is not recommended. Such ties interfere with following work, for example the movement of a mobile elevated working platform (MEWP) used to erect the purlins.

KEY POINTS - Bedding

To ensure that the bedding behaves in accordance with the designer's assumptions, the designer and, particularly, the site team should respect the following recommendations:

- specify grout holes in large plates
- provide good access for the placement operation
- prepare, and adhere to, a method statement for placing
- mix the bedding material properly.

6.1.3 Post-drilled bolts

A variation on the holding-down bolt system described above is one where holes are drilled into the concrete and bolts are then fixed into these holes. Diamond drilling can be used to penetrate both the concrete and reinforcement. The consequences of cutting one or two of the reinforcing bars are not significant for a base slab. However, diamond drilling is a specialist operation which is time consuming and therefore expensive. To avoid diamond drilling, the slab reinforcement must be accurately fixed to avoid clashes with the bolt positions. Post-drilled bolts may prove less convenient than cast-in bolts in terms of the construction programme.

6.1.4 Cast-in columns

A third possibility for the column/foundation interface is to leave voids in the base slab into which the columns can be lowered. The columns are subsequently cast-in to the base. Practical difficulties associated with correctly positioning the columns using this method may outweigh its advantages.

ACTIONS - Foundations

The designer should endeavour to:

- keep the details simple
- provide a means of adjustment to accommodate different tolerance requirements for the foundation and steel frame
- consider all loading scenarios, including erection, to ensure that column stability can be maintained at all times
- manage the interface.

6.2 Concrete and masonry elements

When reinforced concrete or masonry elements are present in a building, the steelwork designer can profit by using these stiff elements to resist lateral loads. A typical example is a building with a reinforced concrete lift shaft, to which the steelwork can be attached. Similarly, masonry walls forming in-fill panels between steel columns can replace bracing members by providing in-plane stiffness.

The ideal position for a shear wall is on the line of the lateral loads, to avoid eccentric loading. Examples of structurally efficient and less efficient locations are shown in Figure 6.2. Clearly, there will be many other constraints on the position of a wall or lift shaft which may make eccentric loading unavoidable. In such cases the steel frame will require some additional bracing members to prevent torsional displacement of the building. The position of this additional bracing for the particular examples is shown in the figure. The mechanism by which the bracing resists torsion is also indicated for one of the examples.

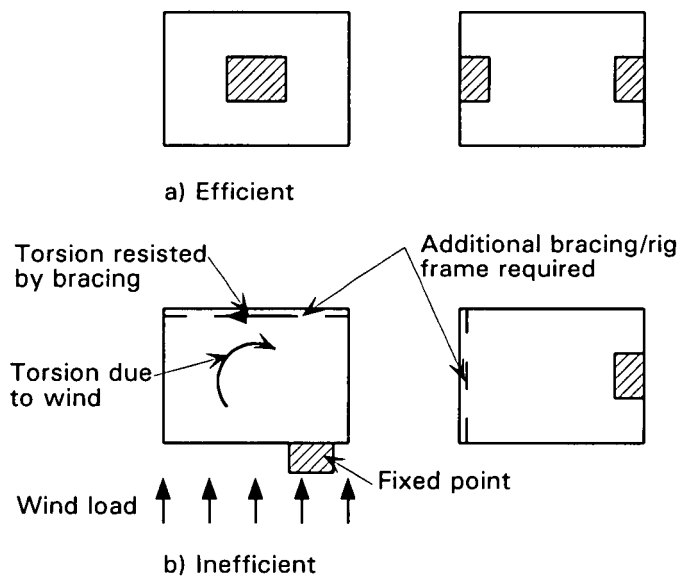

Figure 6.2 *Examples of shear wall location*

6.2.1 Points to consider

A number of points must be considered when using reinforced concrete or masonry elements structurally in a steel framed building.

Even with careful programming, the speed of building construction may be compromised, because the speed of construction of concrete or masonry elements is significantly less than that of the steel frame. If the concrete or masonry elements are not constructed prior to erection of the steelwork, temporary bracing will be needed to stabilise the frame.

Responsibility at the interface must be clearly defined. Although the steelwork designer knows the magnitude of forces to be resisted, he may not be, or may not wish to be, responsible for the design of concrete or masonry elements.

Tolerances for concrete and masonry elements are less onerous than those for the steelwork; according to NSSS requirements, a wall face should be within ± 25 mm,

Chemically bonded anchors may also be considered. Reference should be made to manufacturers' information for capacity and detailing requirements for all types of anchor. To provide greater bolt spacing, the anchors may be used with an attachment plate detail, as shown in Figure 6.4.

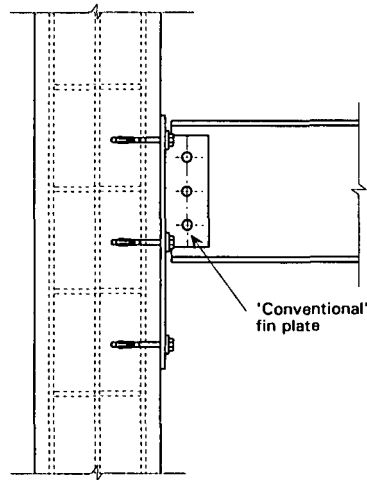

Figure 6.4 Attachment plate fixed to wall using proprietary anchors

A heavily loaded beam may be supported by an attachment plate cast into the wall. A seating angle welded or bolted to the plate is used to locate the beam during erection. Final connection is then made using a detail similar to a standard beam-to-column connection (with a fin plate, cleats or an end plate welded to the embedment). Shear studs welded to the back of the plate transfer loads into the concrete, as shown in Figure 6.5.

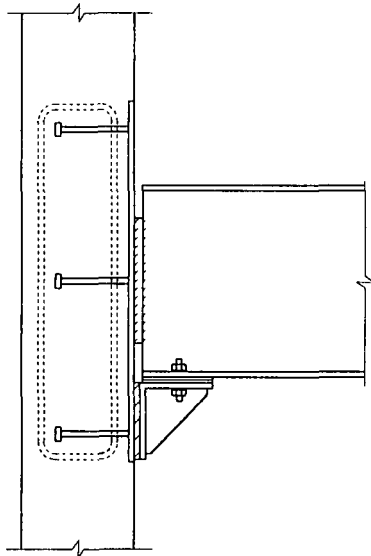

Figure 6.5 Attachment plate cast into wall

The steel frame can be attached to masonry infill walls using a range of proprietary fixings. These are basically the same as those used to retain brickwork panels, as discussed in Section 7.6. Typical examples are shown in Figure 7.6. To resist lateral loads on the frame the masonry panel must be butted-up to the columns, so that lateral movement of the steel frame is resisted by compressive forces in the masonry, rather than tensile forces in the ties. Consideration may need to be given

to thermal or moisture expansion of the restrained masonry panel in some situations.

ACTIONS - Concrete and masonry elements

The designer should:

- carefully consider the construction programme if relying on elements external to the steel frame for bracing
- provide a means of adjustment which can accommodate the different tolerance requirements for the different materials
- design and detail connections between the different materials which can reasonably be made on site
- manage the interface.

6.3 Timber elements

Timber may be used for the secondary elements in a building frame, such as rafters, purlins, ceiling joists and floor joists. Suggested connection details at interfaces between these elements and the steel frame are illustrated in Figure 6.6. These details are simple and self explanatory.

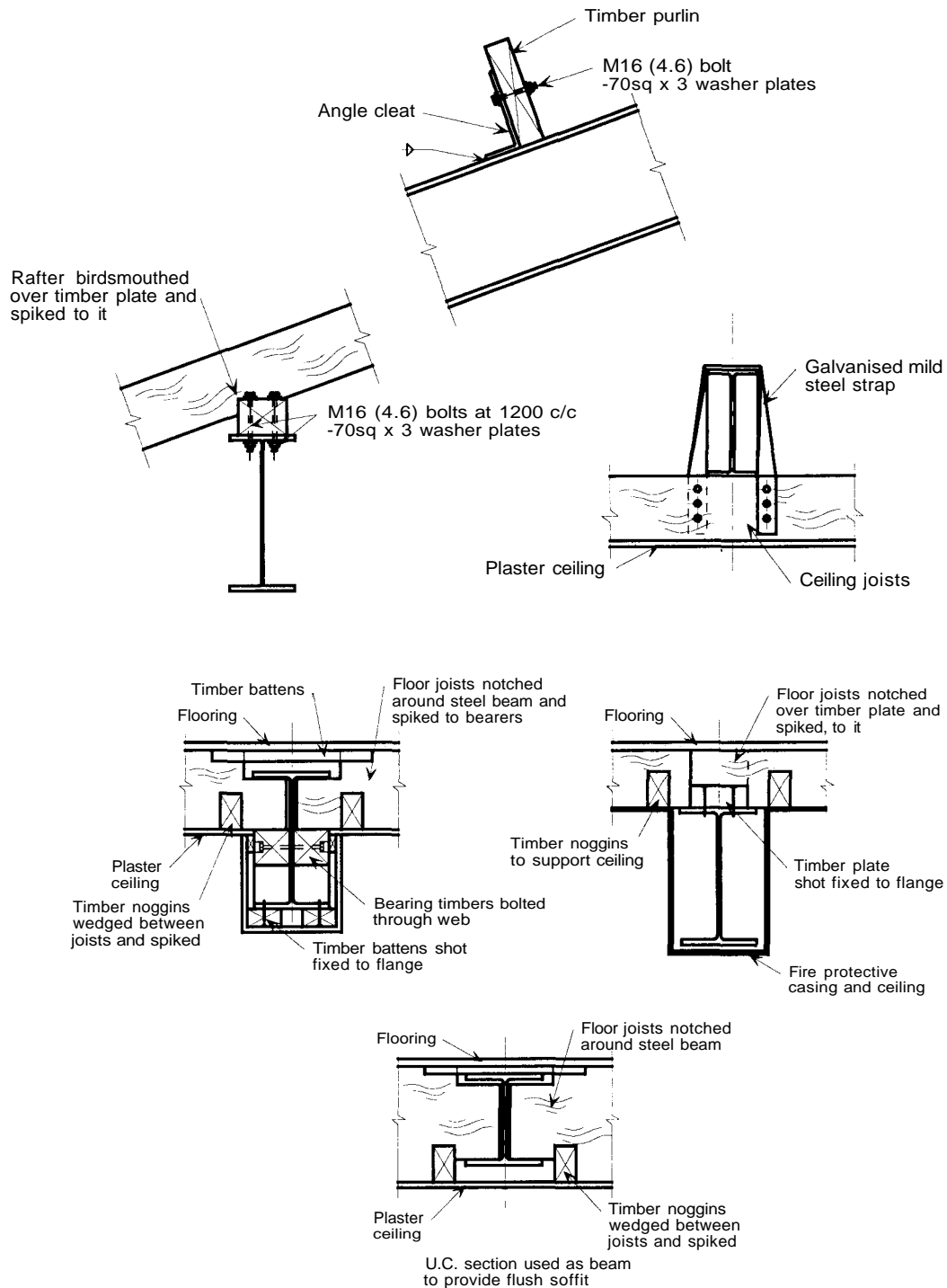

Figure 6.6 Attachments between timber and steel elements

6.4 Composite beams

It is possible to reduce the depth of the structural floor for a given span by utilising composite action between the concrete slab and steel beams. This can result in a saving of 30% to 50% in steel weight compared to a non-composite alternative. In addition to savings in the frame itself, secondary benefits of shallower floor construction include greater flexibility to route services under the structural floor. Various composite beam options, with a summary of their relative merits, are presented in Section 3.3.

Composite beams are normally, but not always, used in conjunction with composite slabs. The latter are generally formed using profiled steel decking and in-situ concrete. The use of lightweight concrete reduces the dead load of the slab. Lightweight concrete also undergoes less shrinkage and has a higher tensile strain capacity than normal weight concrete, so larger pours can be adopted. Alternatively, precast concrete units can be used to form the slab, as discussed separately in Section 6.5.

An alternative type of composite beam is one using a slim floor system. One current system uses a wide plate welded to the bottom flange of the steel beam to support deep decking or precast concrete units within the depth of the beam (see Figure 6.12). British Steel will also be launching a range of 'asymmetric' beams in May 1997. These will be rolled with differing flange widths. The advantages of a slim floor system are described in Section 6.5, with specific reference to the use of precast units.

The Sections that follow refer to the most typical type of composite beam, namely one which is used in conjunction with a composite slab, and therefore has steel decking present between the beam top flange and the concrete.

6.4.1 Erection

The main advantage of using steel decking at the erection stage is that the decking can be used as unpropped permanent formwork when the supporting beams are at not more than 3 m to 3.5 m centres. For greater spans, propping, or a deck with a 'deep' profile, is needed. The designer should adopt a framing plan to reflect the fact that the decking is only one way spanning (using a regular grid, with orthogonal beams where possible).

The sheets are laid out as erection progresses up the building. In this way the decking provides a working platform at each floor level, thereby eliminating the need for temporary platforms. It also serves as a crash deck to protect operatives working at lower levels from small objects, and it reduces the effective height at which erectors must work. A typical erection sequence for a multi-storey building is outlined in Section 4.1.4.

For speed of erection, the decking is normally secured to the beams using shot-fired pins. This positive attachment helps to maintain the stability of the steel frame during erection, and laterally restrain the top flanges of the beams during casting of the slab. At the ends of each sheet, the pins should be placed at 300 mm centres, but over intermediate beams the spacing can be increased to 600 mm. If the decking is required to act compositely with the beam, additional attachment is required. This is usually achieved by through-deck welding of the shear connectors (see below).

Sheets are lifted in bundles onto the frame using a crane, and are then light enough to be individually man-handled into position. This is not possible with precast planks. Sheets can be cut on site to fit details such as column locations. If the sheets are not supported by beams framing-in to the column then seating angles should be welded to the column sides to provide support.

KEY POINTS - Erection

Most composite beams are used in conjunction with composite slabs, the latter being based on profiled steel decking. Principal benefits during erection are that:

- the decking is lightweight and therefore easy to place
- the decking can serve as unpropped, permanent formwork
- the decking provides a working platform.

6.4.2 Shear connectors

Welded shear studs (Figure 6.7) are normally used to develop composite action between a floor slab and supporting beams. The most commonly used studs have a shaft diameter of 19 mm, and are 100 mm long overall (although a range of sizes is available). The studs have a larger diameter head to achieve the necessary force transfer, and are attached using a special welding gun. For buildings, the designer should choose a uniform stud spacing for simplicity (unless there are heavy concentrated loads).

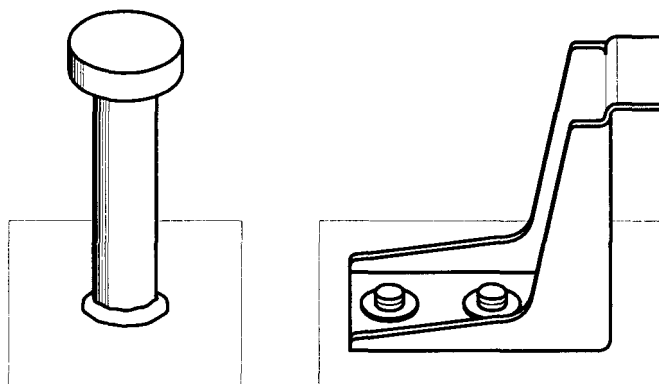

Figure 6.7 Shear connectors (left) welded headed stud, (right) shot fired

Normal UK site practice is to attach shear studs to the steel beam by through-deck welding; the stud is welded to the beam flange by burning through the decking during the welding process. The flange thickness should not be less than 8 mm (for 19 mm studs), unless a single row of studs is welded directly above the web. To achieve a good weld, the flange surface and decking must be free from paint, dirt and moisture. This may prove difficult in some situations. Through-deck welding ensures that the decking is well anchored to the beam, and can therefore be taken into account by the designer when he determines the required transverse slab reinforcement.

Site welding of the shear studs to the beam requires the top surface of the beam flange to be left unpainted during fabrication. When decking ribs run perpendicular to the beam, areas will remain unpainted following completion. This is not a problem unless the beam is in a corrosive environment (for example outdoors, or part of a swimming pool roof). The same areas of the beam may also be left free from fire protection for many situations⁽⁴⁹⁾. This is because the steel top flange is near to the plastic neutral axis and therefore makes a relatively minor contribution to the moment resistance of the composite section.

An alternative to through-deck site welding is to weld the studs to the beam in the fabricator's works. This may have implications for the fabrication programme. If the designer specifies shop welding, holes must be cut in the decking so it can pass over the studs. Alternatively, the steel decking must be cut on site at each beam and butted-up to the line of studs. As a consequence, all the decking is simply supported, reducing its efficiency, and the ends of the decking ribs must be sealed to prevent concrete loss during casting of the deck. Shop welding is not often adopted in the UK.

Test procedures are specified in the NSSS for ensuring that the studs are correctly welded to the beam flange, and therefore provide shear resistance and ductility which are compatible with the designer's calculations. All welds should be visually inspected. In addition, at least 5% of the studs should be bent a lateral distance equal to approximately one quarter of the stud height using a hammer. The welds are then checked for any signs of cracking or lack of fusion. There is no need to straighten these studs after testing. Weld quality may also be assessed by tapping the studs with a hammer and listening to the ringing tone.

Occasionally, when site conditions dictate, shot-fired shear connectors may be used (Figure 1). These eliminate the need for site welding, and so are appropriate in certain circumstances:

- small projects where the limited number of connectors does not justify the semi-skilled labour and plant needed for welding studs,
- when it is not possible to adequately clean and dry the flange before the connectors are fixed.

As for welded studs, the designer must respect codified rules for the layout of the connectors; the transverse spacing (perpendicular to the beam axis) between connectors must be at least 50 mm, and the longitudinal spacing between 100 mm to 600 mm.

The principal disadvantage of shot-fired connectors, which currently (1996) cost approximately £1 per applied connector, is that they only have around half the strength of a 19 mm welded stud. Provided a sufficient number are needed, 19 mm welded studs can be fixed for a similar price.

6.4.3 Decking

Some typical examples of decking profiles are shown in Figure 6.8. These fall into two basic categories, dovetail and trapezoidal. The designer's choice of decking is influenced by several factors, as discussed below.

The required fire resistance of a slab is achieved by limiting the conduction of heat to the upper surface of the slab, and by including within the slab an appropriate amount of reinforcement. The conduction is affected by the insulating thickness of concrete, the decking profile, and the type of concrete. The designer must specify an appropriate combination of thickness, decking and concrete to achieve the required fire resistance. Table 6.1 quantifies insulation thickness requirements for different cases, but structural considerations will often determine the final slab thickness.

The amount of reinforcement required in a slab depends not only on the loading, but also on the required fire resistance. Normally a single layer of mesh (minimum A142) is needed. For additional information see Reference 49.

Table 6.1 *Insulation thickness requirements (all values for lightweight concrete)*

Fire resistance period (hours)	Insulation thickness * (mm)	
	Trapezoidal	Dovetail
0.5	50	90
1.0	60	90
1.5	70	105
2.0	80	115
3.0	100	135
4.0	115	150

* For trapezoidal profiles the insulation thickness is the depth of concrete above the top of the decking ribs. For dovetail profiles it is the overall depth of slab.

The self weight of the slab clearly depends on the volume of concrete used. This is a function of the slab thickness and the decking profile, which determines the volume of voids in the slab. Slab thickness is primarily a function of structural and fire resistance requirements. Dovetail profiles generally require a shallower overall slab depth for a given fire resistance.

The form of the decking ribs has an influence on the ease with which services can be hung from the ceiling. Several profiles offer the facility to fix hangers within the ribs. This may be a particularly useful feature, because services can then be suspended from virtually any part of the soffit.

When decking is present, the capacity of the shear connectors is influenced by the orientation and geometry of the decking ribs. For ribs running perpendicular to the axis of the beam, the connector capacity is less in a rib which is narrow relative to its own height (see Figure 6.9a), or a rib which is high relative to the connector height (see Figure 6.9b). This may have an influence, albeit small, on the number of connectors which are needed. Connector strength is also reduced when there are multiple connectors per rib (see Figure 6.9c).

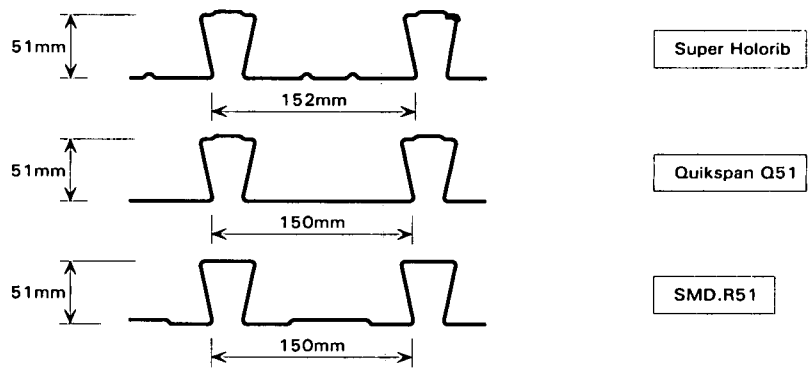

a) Dovetail

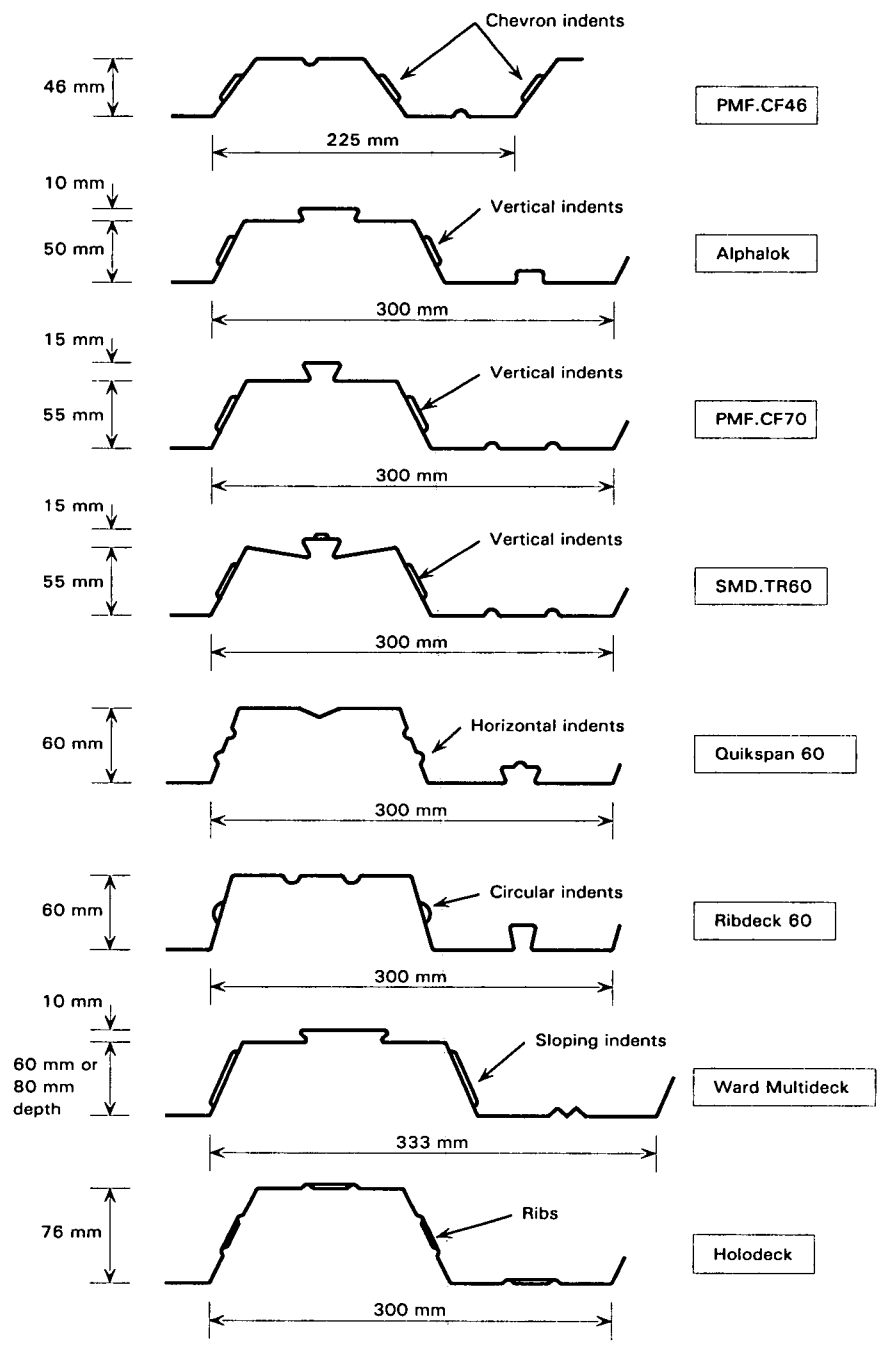

b) Trapezoidal

Figure 6.8 Typical examples of decking profiles

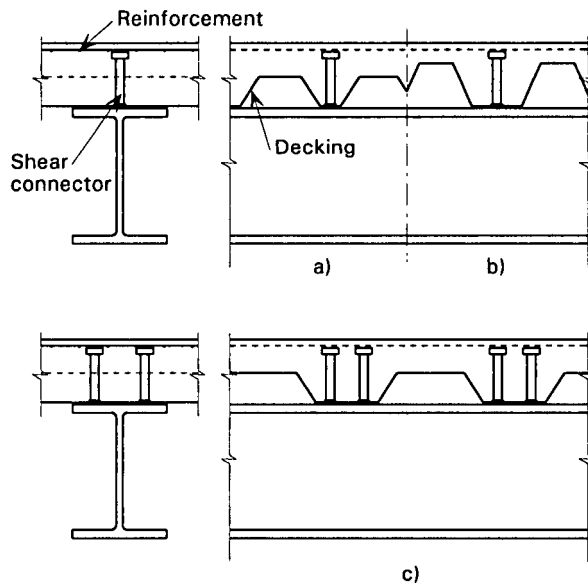

Figure 6.9 Influence of decking on shear connector strength (a) decking with large height to width ratio, (b) high decking, (c) multiple connectors per rib

Forming holes in the slab is a simple procedure. A box-out is left during concreting (see Figure 6.10) and then a ‘nibbler’ is used to cut an opening in the decking once the concrete has cured. It is not necessary to protect the cut metal edges against corrosion, because galvanising provides a sacrificial coating (zinc is lost from adjacent areas in preference to the steel corroding). It may be necessary to detail additional reinforcement around the opening when its side length exceeds 150 mm.

When holes are formed adjacent to composite beams, consideration must be given to the fact that the slab acts as a structural beam flange within a certain effective width (one quarter of the span for a simply supported beam). In theory, the designer should consider the reduced flange width when calculating the beam moment resistance. However, in practice this is often not a problem, because holes are generally formed near to walls, i.e. near the beam ends. In such locations the width of flange actually needed is significantly less than the nominal effective width.

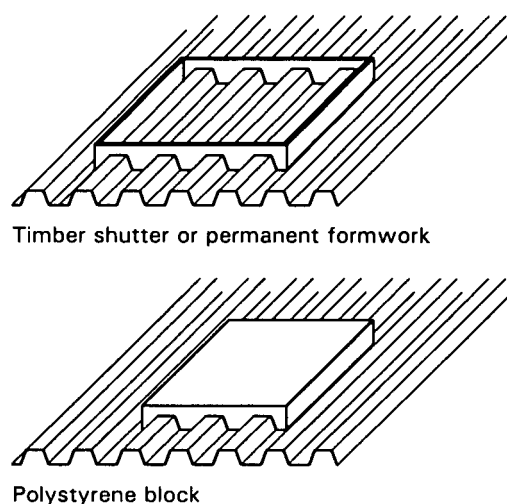

Figure 6.10 Hole forming in a composite slab

Edge details

Edge trims are formed from galvanised pressed sheet and supplied in standard lengths for various depths of slab. Lengths are cut on site to suit column positions etc. The designer must specify edge details which comply with certain criteria. The trims must be tied back to the decking by straps at 0.6 m to 1.0 m centres, depending on the slab depth and overhang of the decking from the edge beams. The distance which the slab may cantilever beyond the edge beams is dictated by the orientation of the decking ribs. When the ribs run perpendicular to the beam axis, the decking can cantilever up to 600 mm. For ribs running parallel to the beam axis, a support must be provided when the overhang exceeds 160 mm. Typical edge details are shown in Figure 6.11.

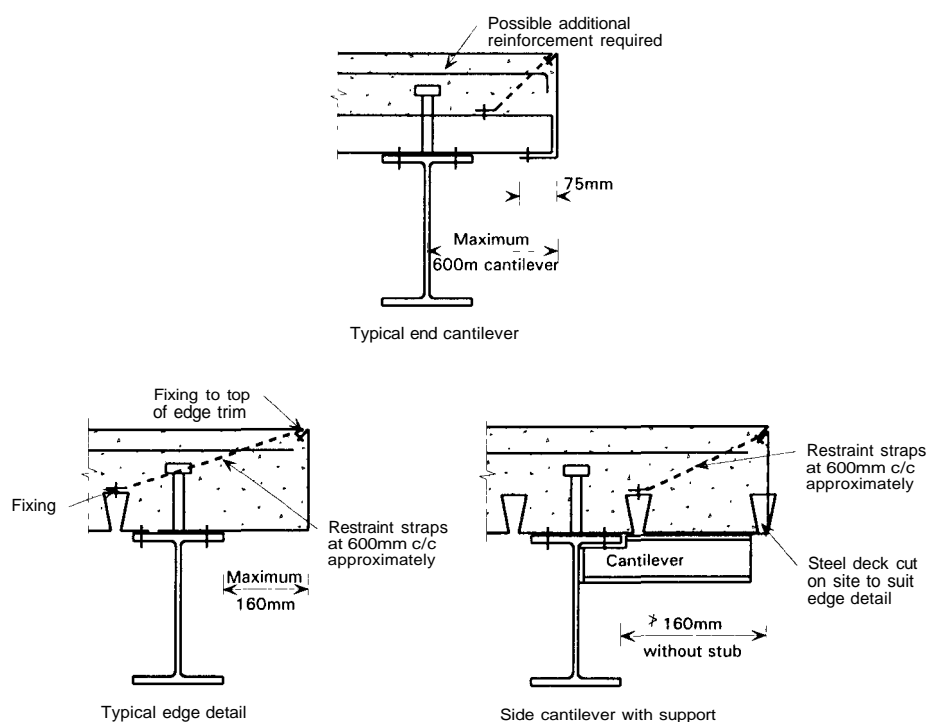

Figure 6.11 Typical slab edge details

ACTIONS - Composite beams

Composite beams are normally specified for use in conjunction with composite slabs. Profiled steel decking is used to span between the beams. The designer should:

- arrange the frame members so that the decking can be used as unproped, permanent formwork
- specify through-deck welding of the shear connectors
- choose appropriate decking for the required performance
- beware of holes being cut in the slab adjacent to beams.

6.5 Precast concrete floors

Floors can be constructed using precast concrete units. These units may be supported on the top flange of a steel beam, or on shelf angles attached to the beam web. Alternatively, when a slim floor system is adopted to minimise the structural floor depth, the units may be supported on a wide bottom flange, or a wide plate welded to the bottom flange of a standard I section beam. Typical details employing precast units are shown in Figure 6.12.

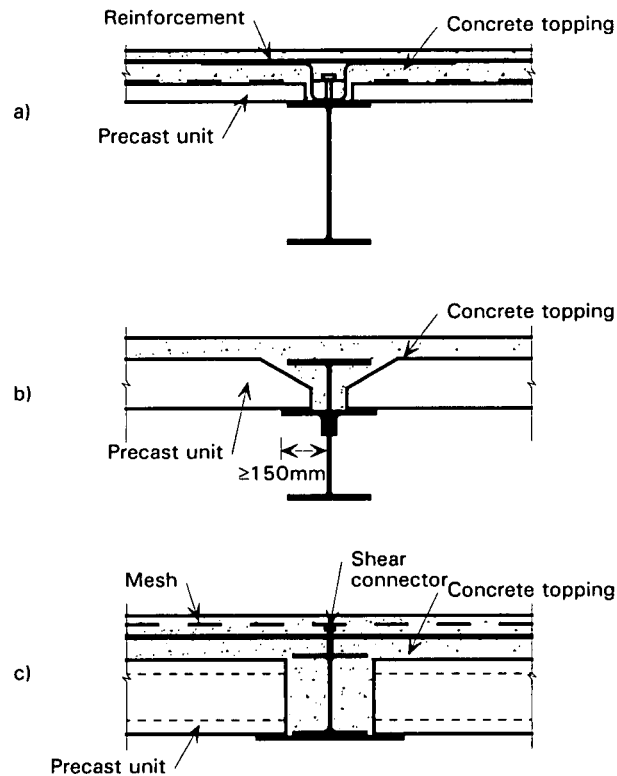

Figure 6.12 Typical details employing precast concrete units supported on (a) top flange of the beam, (b) shelf angles, (c) slim floor beam

A cross-section in which precast planks sit on the top flange of a steel beam is shown in Figure 6.12a. The designer must respect certain detail requirements when specifying such a system. BS 8110⁽⁸⁷⁾ requires a minimum seating length of 50 mm for planks which are tied together. If the planks act in isolation 75 mm seating is required. These values include an allowance of 10 mm for variations in length and position of the planks. Reference should be made to the code BS 8110, or manufacturers details, for more information. Composite action may be achieved by fixing a line of shear connectors along the centre line of the beam and casting concrete around these and the planks. Reinforcing bars running across the flange and into voids in the planks (see Figure 6.13), or over the planks, prevent the connectors punching horizontally through the slab as the beam deflects under load.

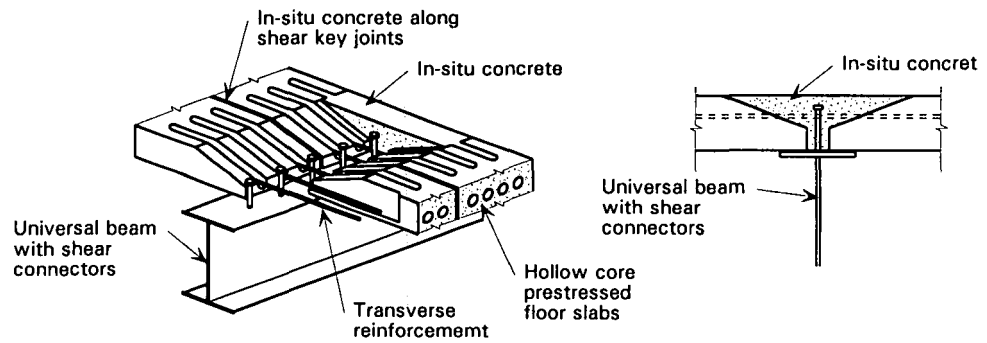

Figure 6.13 Reinforcement detailing with precast slabs

Precast planks can be supported on shelf angles bolted or welded to the beam web. To provide the necessary seating, and ensure that the planks can be dropped into position below the beam flanges, a minimum angle outstand of 150 mm is needed (Figure 6.12b). Angles should project 25 mm beyond the top flange of the beam if this is more than 250 mm wide. Care should be taken to ensure that the contact faces of the web and angles are protected against corrosion in situations where this may cause a problem (for example outdoors).

Figure 6.12c shows the cross-section of a composite slim floor beam. In-situ concrete cast around the precast units is used to transfer longitudinal shear between the beam and slab via shear connectors. Similar non-composite sections employ either a grout or in-situ concrete infill around the steel beam, and do not require an in-situ topping. Deep steel decking can be used instead of the precast units in a section which is otherwise similar. Particular advantages of slim floor construction include a high span to depth ratio, a smooth soffit (when precast planks are used), and good inherent fire resistance.

One of the advantages of any floor system using precast concrete units is that they can span 8 m or more. This allows a considerably greater secondary beam spacing than when steel decking is used to form a composite slab.

Disadvantages include the fact that the units require a crane for individual positioning on site, due to their self weight of 250 kg to 500 kg per metre span. When erecting precast units, a sequence of placing them alternately either side of internal beams should be specified to avoid the need to design the beams for torsion.

Unlike steel decking, precast concrete units are not positively fixed to the steel beams. However, prior to the placing of in-situ concrete between the units, restraint is provided by the restoring moment which develops if the steel section starts to buckle. The designer may assume that beams up to 8 m in length are fully restrained by this mechanism (see Figure 6.14). For edge beams, there may not be a restoring moment, and special provision may be needed to give lateral restraint. Frictional forces alone should not be relied upon to laterally restrain the beams during construction when significant loads are applied (although wide precast planks do provide some frictional restraint)⁽⁵¹⁾.

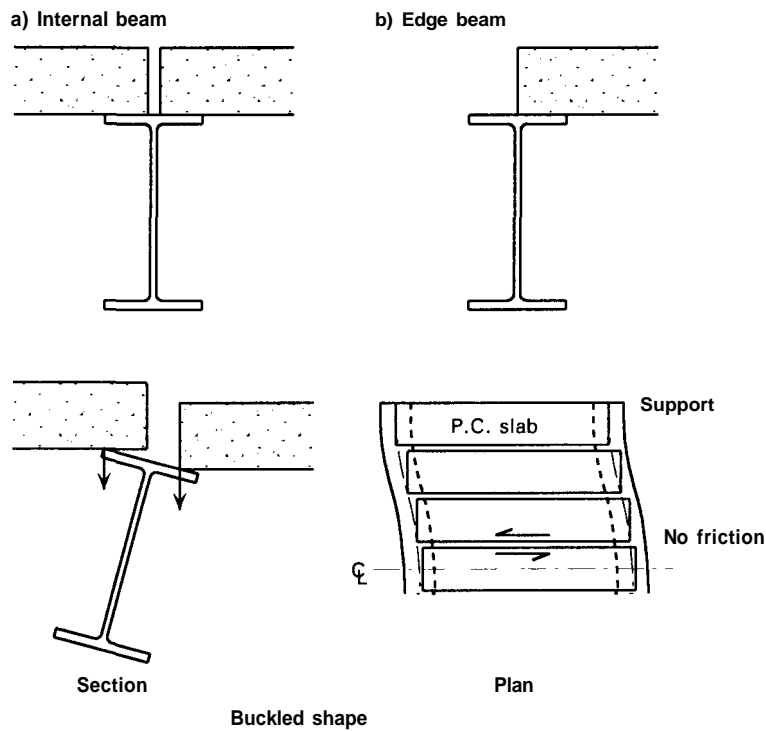

Figure 6.14 *Beam restraint provided by precast concrete slabs*

ACTIONS - Precast concrete floors

When specifying the use of precast concrete floor units, the designer must:

- consider how the units will be manoeuvred into position, and leave appropriate clearances
- consider how lateral restraint will be provided to the beam top flanges during construction
- ensure that the erector understands the need to place the units in a sequence which prevents torsional loads, in excess of those considered in the design, being introduced into the beams.

6.6 Crane girders and rails

A typical crane detail is shown in Figure 6.15. In this example, the girders are supported on brackets attached to the main columns. An alternative would be to support the girders on dual columns. Although design of the girders is normally the responsibility of the structural designer, specialist suppliers are often used to provide a complete design and on-site installation service for the rails and fixings.

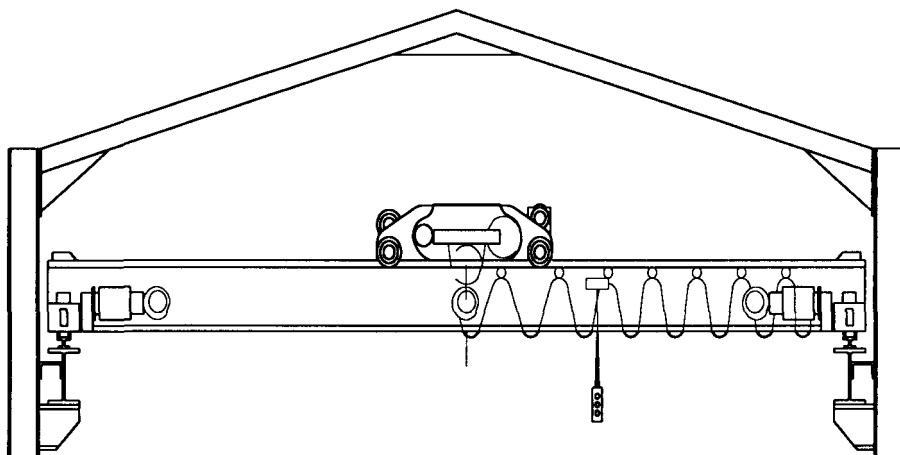

Figure 6.15 *Double girder pendant controlled crane for loading class Q2*

6.6.1 Crane classification

The appropriate British Standards (BS 466⁽⁸²⁾ and BS ,2573 ⁽⁸³⁾) classify cranes according to two criteria:

- Q1 to 44 according to the proportion of lifts which are close to the safe working load (SWL); a low proportion for Q1 cranes, a high proportion for Q 4 cranes
- U1 to U9 according to the frequency of use; U1 to U3 are used infrequently, U7 to U9 almost continuously.

Classes for some typical applications are given in Table 6.2, which is taken from BS 466. The class dictates the load factors to be used in design (reference should be made to the appropriate standard for more details), and the required design considerations. For example, according to BS 5950: Part 1 ⁽⁸⁵⁾, crabbing of the trolley need only be considered for classes 43 and 44. This standard also recommends that for these two classes manufacturer's information is sought before calculating dynamic and impact loads. Less accurate design is acceptable for classes Q1 and Q2, which operate close to their SWL less frequently.

Table 6.2 *Typical classification for overhead travelling industrial type cranes*

Type and/or application	Class of utilisation	Class of loading
Cranes for power stations	U2 - U4	Q1
Light work shop duty (maintenance, repairs, assembly)	U2 - U4	Q1 - Q2
Light stores duty	U2 - U4	Q1 - Q2
Medium and heavy duty (workshop, warehouse)	U4 - U6	Q1 - Q3
Crane for grabbing work	U5 - U8	Q4
Ladle crane for foundry work	U4 - U5	Q3 - Q4
Magnet crane for stockyard work	U5 - U6	Q2 - Q3
Magnet crane for scrapyards work	U5 - U6	Q3 - Q4
Process crane	U6 - U7	Q2 - Q3
Shipyards crane	U5 - U6	Q2 - Q3

6.6.2 Girders

In addition to vertical loading, the crane girders need to be designed to resist horizontal loads. The designer may need to consider improving the lateral resistance of the girder top flange using a plate or even a channel section seated over the flange.

Although rail fixings usually permit adjustment of the rail relative to the girder, the adjustment of line which is provided by the rail fixing should not exceed the greater of ± 6 mm, or half the web thickness, according to ENV 1090-1⁽⁸⁸⁾. This limit is necessary to avoid introducing large eccentric loads into the girder. To accommodate any greater deviation, the structural designer should make provision for the position of the girders themselves to be adjustable.

6.6.3 Rails

Crane rails are available in standard section sizes⁽⁵²⁾. The choice of rail section depends on the load to be carried and the wheel diameter. For light loads, steel bars are often used as 'rails'. Rails may be continuous, or detailed in lengths to suit simply supported girders.

Adjacent lengths of individual rails may be butted-up or scarfed (see Figure 6.16a & b). A scarfed detail reduces the change in slope of the rail as a wheel passes over the joint, allowing a smoother passage of the trolley. The rail joint should be offset from the adjacent joint in the girder.

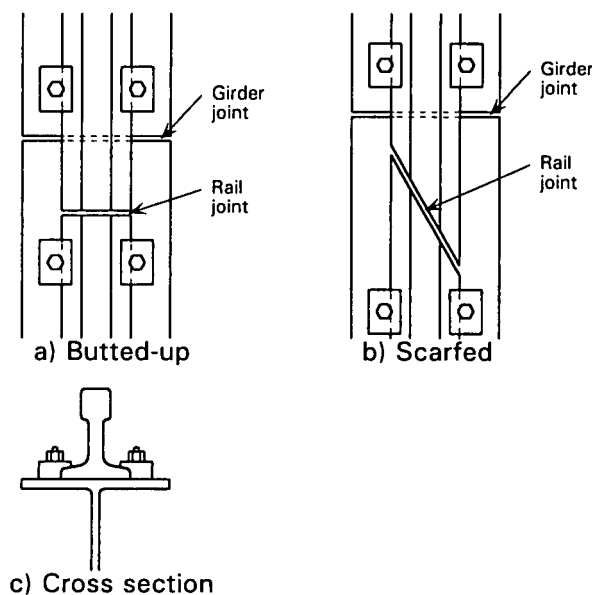

Figure 6.16 Crane rail details

Continuous rails may be formed by joining adjacent lengths using fish plates. Alternatively the rails may be welded, but depending on the type of steel this may require a special procedure.

Tolerances for crane rails are more onerous than those for steel building frames. A comprehensive set of geometrical and dimensional tolerances is given in Appendix F of BS 466 *Specification for Power Driven Overhead Travelling Cranes*⁽⁸²⁾. The NSSS suggests an alternative tolerance on deviation from the true gauge (± 10 mm), and on the step in running surface level at joints in the rails

(0.5 mm). It should be noted that satisfying the criteria in the NSSS would not in itself ensure compliance with BS 466⁽⁸²⁾. The NSSS tolerances should be used as a basis for positioning the crane girders, but the requirements of BS 466 will need to be considered when positioning the rails. Precambering of the girders to achieve the right rail level is not recommended, since this may result in a ‘bow wave’ ahead of the crane.

6.6.4 Fixings

The type of fixings used to connect the rails to the girders must be appropriate for the application. The following guidelines should be considered.

For light duty applications, bars may be welded to the girder top flange. Alternatively, to avoid welding or the need for drilling the flange, clips which wrap around the flange may be used to locate and secure the rail.

For light to medium duty applications, with infrequent crane use, the crane rail may be attached using ‘hard clips’. These are bolted to the flange, or attached to threaded studs welded to the flange (Figure 6.17). They are unsuitable for cranes which are used frequently because stress cycles occur in the bolt/stud upon each wheel passage, causing fatigue.

‘Expansion clips’ are particularly recommended for heavy duty applications, but may be used generally. Vertical clearance between the rail and clip (see Figure 6.17) allows limited movement of the rail without inducing fatigue stresses in the clip. This clearance also permits longitudinal expansion of the rail. A resilient pad may be used to reduce noise and vibration, and to reduce load concentrations and stress levels. A pad is essential for outdoor applications to prevent fretting corrosion.

‘Spring clips’ (Figure 6.17) are also used for heavy duty applications, but are often less economical than expansion clips. They are particularly suitable for long, continuous rails. The springs allow limited vertical movement of the rail, independent of the clip. A resilient pad may be used if required.

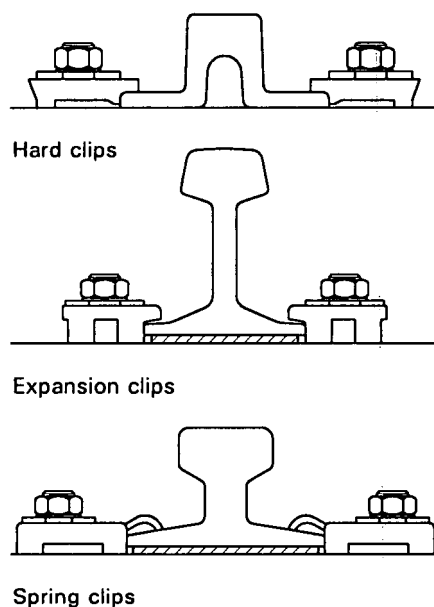

Figure 6.17 *Various types of crane rail fixings*

ACTIONS - Crane girders and rails

The 'simplicity' of the crane girders, rails and fixings depends on the class of crane to be used. The structural designer should consider the following points:

- specify fixings which provide a means of adjustment for the rails relative to the girders
- provide an independent means of adjustment for the girders, to accommodate greater deviation
- use a specialist to provide a complete design and installation service for the rails and fixings.

6.7 Cold formed sections

Cold formed sections can be used, amongst other things, as an alternative to timber for the secondary elements in a building frame. Currently their main structural use is as purlins and side rails for industrial buildings. These uses are similar and described below. A list of several new developments of cold formed section use in housing, light industrial and commercial buildings is given at the end of this Section.

6.7.1 Purlins and side rails

Purlins are often of Z (or similar) shape. The web of a Z section is close to the vertical when the section is used to support a pitched roof. This ensures that vertical loads do not cause serious twisting of the section, for slopes of 10° to 15° . However, roof slopes in modern industrial buildings can be as low as 5° , and this has created a need for modified sections. The so-called 'Zeta' section is one attempt to provide a section shape more suitable for shallow roofs. C shaped sections and their derivatives (for example E) are also widely used for roof and wall applications. The web shape can be modified to reduce twisting of the section by bringing the shear centre closer to the web. Examples of cold formed steel sections are shown in Figure 6.18.

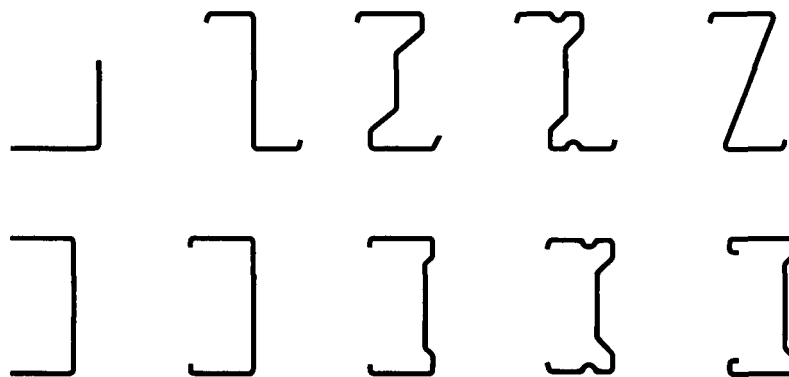

Figure 6.18 *Examples of cold formed steel sections*

Manufacturers often produce sections for specific uses, and base tabulated design information on test data rather than calculations. This enables section use to be

optimised. Manufacturers also generally provide a full range of ancillary components for use with their sections. The designer's job is then a simple one of picking suitable components to suit the requirements, from a catalogue.

Detailing

Depending on their section size, span and the roof slope, purlins may need to be provided with sag rods. These prevent twisting during erection, and stabilise the lower flange against wind uplift. Different details are used to fix these rods to the purlins (see Figure 6.19). The designer should consider the ease with which the system can be erected, as well as its structural performance, when specifying a detail.

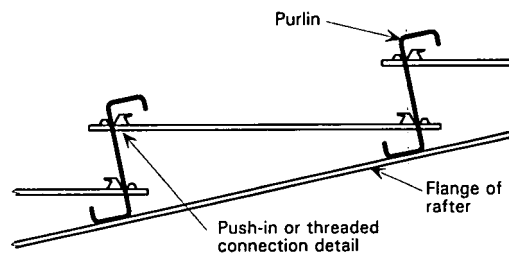

Figure 6.19 *Purlins with sag rods*

Lateral forces on the members can usually be resisted by diaphragm (or 'stressed skin') action of the roof sheeting, so the upper flanges of the purlins can be considered to be laterally restrained by the sheeting when appropriate fixings are used.

Purlins are usually made continuous in order to reduce deflections, but when elastic design is used to size the continuous purlins, an overly conservative section often results. This is because support moments predicted by an elastic analysis are significantly greater than span moments, and the section must clearly be able to resist the greater of the two. In reality some moment redistribution occurs, reducing the imbalance of applied moments and therefore reducing the size of section needed.

Often the most economical way to determine the behaviour of a purlin, allowing for moment redistribution, is by testing. Manufacturers have developed overlapped and sleeved systems, based on testing, which provide increased moment resistance and ductility at supports (see Figure 6.20). Overlaps provide greater moment resistance than sleeves, but they are more expensive because they need to extend further into the span, and this can complicate erection.

When designing for construction, the designer should consider not only ways in which to optimise section behaviour, but also ways in which the work on site can be facilitated. Before specifying a system to strengthen purlins over supports the designer must consider the ease of implementation of the various options which are available to him.

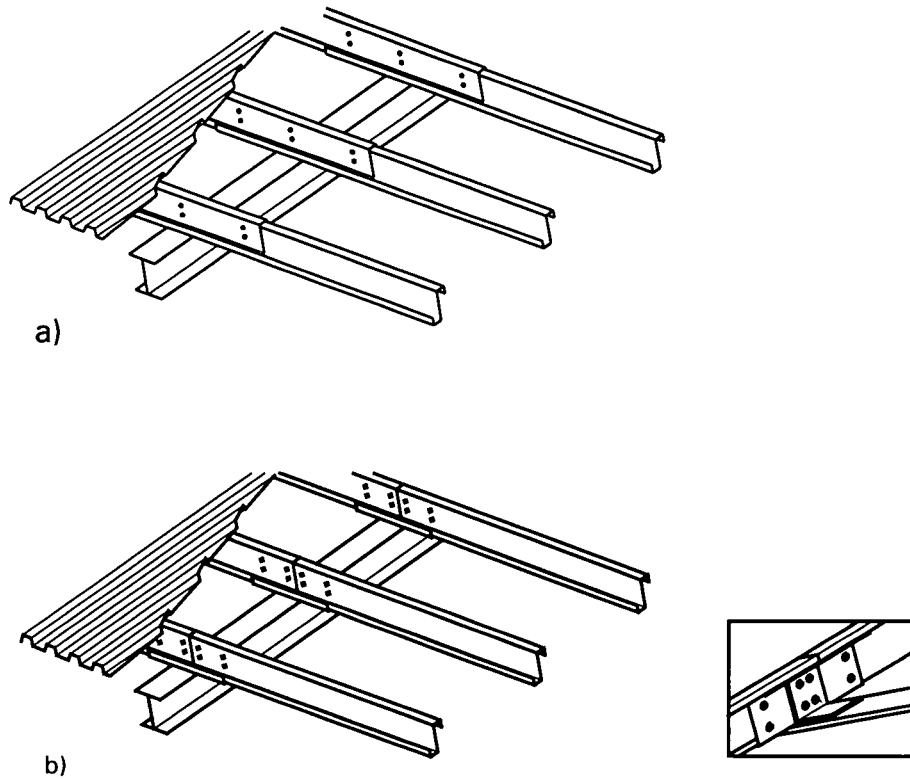

Figure 6.20 *Purlin details at support, a) overlapped b) sleeved*

‘Vertical’ loads are transferred to the supporting rafters via cleats fixed to the web of the purlin. The cleats are designed so that the lower flange of the purlin does not bear directly on the rafter, thereby avoiding web crippling problems. Holes can be punched in the purlins during forming, and bolts are normally used for fixing to the cleats. In almost all cases the strength of the connection is governed by the bearing capacity of the thinner steel section, rather than by the shear capacity of the bolts. Overlapped or sleeved systems provide a double web thickness at supports, thereby improving the shear resistance of the section.

6.7.2 Other uses

Other structural and non-structural uses of cold formed steel sections in buildings include:

- stud walling and partitions
- floor joists
- trusses
- building frames
- curtain walling
- lintels

A detailed discussion of these uses is given in Reference 49.

ACTIONS - Cold formed sections

The designer should:

- use manufacturers' information to minimise design time
- specify systems and details which not only meet structural requirements, but which are also easy to erect
- specify a system with a minimum number of components, to reduce erection time.

6.8 Further reading

(For further information, see Section 9, References)

Foundations

Steel designers' manual⁽³¹⁾. Amongst the extensive information to be found in this book, 27 pages in Section 27 cover foundations and holding-down systems. Subjects covered include foundations, connections to the steelwork, analysis and holding-down systems. Worked examples are included.

Joints in simple construction, vols 1 and 2,^(14,15) and *Joints in steel construction: moment connections*⁽¹⁶⁾. Section 6 (8 pages) of volume 1 includes a design procedure for nominally pinned bases. Section 7 (18 pages) of Volume 2 includes examples. For moment resisting bases, principles, procedures and a worked example are given in Section 6 (17 pages) of the moment connections publication. See also Further Reading in Section 2.4.

Connections between steel and other materials⁽⁴⁸⁾. Section 2.3 presents a connection detail for a steel column to a new concrete foundation. See Further Reading in Section 4.4 for more information.

The National Structural Steelwork Specification for Building Construction, 3rd edition⁽⁶⁾. Presents tolerances for foundation level and holding-down bolt positions. See also Further Reading in Section 2.4.

Holding down systems for steel stanchions⁽⁵⁴⁾. Although dated, this still contains useful information.

Concrete and masonry elements

Connections between steel and other materials⁽⁴⁸⁾. Presents an overview of methods of making structural connections between steelwork and concrete or masonry elements.

The National Structural Steelwork Specification for Building Construction, 3rd edition⁽⁶⁾. Presents tolerances for the position of a wall face, and the position of a cast-in bolt. See also Further Reading in Section 2.4.

Steel construction yearbook 1997⁽⁵⁵⁾. Manufacturers' information should be consulted for details of proprietary anchors.

Timber elements

Steel detailers' manual ⁽⁵⁶⁾. Provides an introduction to draughtsmen, technicians, structural engineers, architects and contractors in the detailing of steelwork. Figure 6.6 is taken from this publication.

Composite beams

SCI publications. Numerous guides covering various aspects of composite construction. Details available from the SCI. Principal titles include:

Design of composite slabs and beams with steel decking ⁽⁵⁷⁾. Presents a method of design consistent with BS 5950: Parts 1 and 3 ⁽⁸⁵⁾ for simply supported composite beams used in buildings. Includes design tables and a worked example.

Commentary on BS 5950: Part 3: Section 3.1 Composite beams ⁽⁵⁸⁾. Covers the background to the code and provides an in depth explanation of its requirements.

Good practice in composite floor construction ⁽⁵⁹⁾. Aimed at site engineers, foremen and operatives, emphasises correct procedures to be followed in order to avoid bad practice.

Steel construction yearbook 1997 ⁽⁵⁵⁾. Manufacturers information provides details of decking and shear connectors. Information on site practice is also available.

Precast concrete floors

Slim poor design and construction ⁽⁵⁰⁾. Presents a method of design for slim floor construction comprising steel beams and concrete slabs located within the depth of the beams. Includes design charts and worked examples.

Lateral stability of steel beams and columns. ⁽⁵¹⁾ The first Section covers the theory of elastic stability of beams and columns. Common cases that are encountered in building construction are presented in the second Section, including a case study of beams supporting precast concrete slabs.

Steel construction yearbook 1993 ⁽⁵⁵⁾. Precast concrete slab manufacturers design and detailing information should be consulted.

Crane girders and rails

The National Structural Steelwork Specification for Building Construction, 3rd edition ⁽⁶⁾. Presents tolerances for rail gauge, and the maximum permissible step in level at a rail joint. See also Further Reading in Section 2.4.

Manufacturers information should be sought for details of rails and clips, for example *The section book* ⁽⁵²⁾ produced by British Steel.

Cold formed sections

Design of structures using coldformed steel sections ⁽⁵³⁾. A design guide for practitioners covering the design and application of cold formed steel sections in general building construction. Includes design tables for section and member properties. Conforms to BS 5950: Part 5 ⁽⁸⁵⁾.

Building design using coldformed steel sections: worked examples to BS 5950: Part 5: 1987 ⁽⁶⁰⁾. A companion publication to above, it covers the detailed design

of beams, columns and trusses. Worked examples include connection design and detailing. Tabulated section properties are given for generic C sections.

Building design using coldformed steel sections: an architect's guide(61). Gives information on the range of light steel framing and cold formed steel products that are used in buildings. Includes manufacturers' addresses and other sources of information.

ECCS has produced a series of guides. Details are available from the SCI.

7 INTERFACES WITH NON-STRUCTURAL COMPONENTS

This Section contains information covering all aspects associated with a given interface, covering both design and construction issues. This information is given so that the structural designer has an understanding of issues which may only touch on his sphere of responsibility, but which may, perhaps unknowingly, be affected by his decisions. Exact limits of responsibility will depend on the procurement process adopted for a particular project.

7.1 Services

Although the design of services is not normally the responsibility of the structural designer, he should be aware how his decisions will affect the design and installation of the services.

Services may represent over 30% of the total building cost, compared with the structure cost of less than 20%”). In highly serviced buildings, the structural designer should therefore give serious consideration to structural systems which facilitate service integration @*) since this can result in major savings in time, cost and conflict. The potential savings may more than outweigh any increase in frame cost.

A beam and slab system which minimises the depth of the structural floors can be used to release a greater volume in which services can be routed, Composite floors employing certain types of steel decking allow services to be hung from the slab at virtually any location. By grouping services into ducts they can be installed in one continuous process, making installation independent of the building operation.

Communication between the structural designer and the services engineer must be effective, with early two-way transmission of final information where possible, so that modifications and delays are avoided. The structural designer needs to be aware of service positions so that he can detail openings, and include the necessary service loading in his design. This is particularly true when services are concentrated in specific regions, because significant localised loading may occur. Unfortunately the services engineer is often appointed late in the design process, so the structural designer may not possess all the final information he requires when designing the frame.

For a high rise building, the structural designer should also allow for the need to support cleaning gantries, safety wires, etc. Clear and early transmission of information to him is necessary, to avoid details for support points being included as an afterthought.

ACTIONS - Services

The structural designer must remember that, depending on the building specification, the cost of the services may be considerably greater than that of the structure. With this in mind, he should;

- design the frame to allow easy installation of the services. One way of doing this is to choose a floor system which releases the greatest space for services
- communicate and cooperate from an early stage with the services engineer, to avoid the need for modifications, possibly on site.

7.2 Lift installation

Lift details have been standardised by all the major manufacturers in the UK⁽⁶³⁾. The structural designer does not therefore need to know the make of lift before commencing the frame design, although involvement of the lift manufacturer as early as possible is still recommended.

The most common type of lift shaft walls in modern steel framed buildings comprise a light, dry lining system. Alternatives are reinforced concrete or masonry walls, but these both suffer from being wet trades, which interfere with the progress of other work. Dry walls are formed from multi-layer plasterboard, or fire resistant board. They facilitate construction because they can be fixed from outside the lift shaft, thus avoiding the use of temporary access platforms. Because the boards cannot carry load, lift installations must be supported from either the floor slabs or the main steel members, possibly via secondary steelwork. The choice of shaft wall therefore affects the loading applied to the frame, as well as the steelwork detailing around the shaft.

There are three interfaces between the lift installation and the building frame:

- guide rails
- door supports
- thresholds (which locate the bottom edge of the doors).

A typical detail for each interface is shown in Figure 7.1. Rails, supports and thresholds are normally designed by the lift manufacturer, with the responsibility of the structural designer being limited to any secondary members which are needed to support these elements.

Vertical guide rails are fixed to brackets which allow horizontal movement. To avoid complications on site, this movement must be sufficient to accommodate any allowed deviation of the steel frame, and keep the rails within tolerance limits. The brackets should not be subjected to vertical loading. Typically, rails span 3 m to 4.5 m vertically for low and medium speed lifts. The section size of the rails should be such that the number of connections is minimal, and if possible all connections should be at floor levels.

Doors must be supported from the steelwork when dry walls are used. The structural designer should keep secondary steelwork as simple as possible, for example by using a U-frame suspended from the floor above (Figure 7.1), rather than an H-frame spanning between floors. Differential movements in service must be accommodated - floor deflections under live load must not prevent the lift doors from opening!

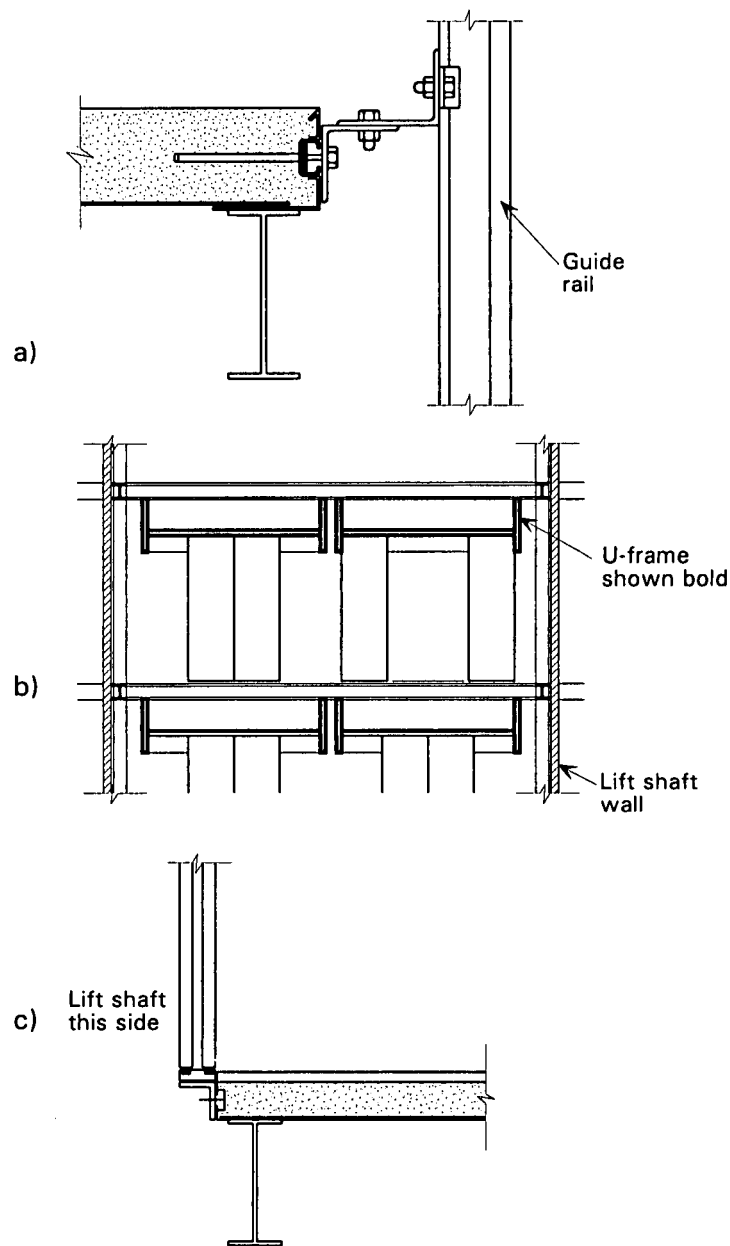

Figure 7.1 *Lift installation connection details, (a) guide rail connection to slab edge, (b) suspended door support steelwork, (c) threshold*

Threshold support steelwork may be cast-in to the floor edge, making due provision for tolerances, or attached to a trimmer beam. Care must be taken to ensure that the ability of the floor to act as a fire barrier is not compromised⁽⁶³⁾.

Additional secondary steelwork will be required in the machine room, and a lifting beam will be required for use during lift installation and maintenance. As with all secondary steelwork, clear limits of responsibility, at the design, construction and possibly testing stages, must be defined and understood by all parties. A lack of clarity can lead to conflict, and possible delays to the construction programme.

The structural designer must consider deflections of the supporting frame under loading from the lift car. BS 5655: Part 9⁽⁸⁴⁾ specifies deflection limits for the rails and supporting structure, under specified levels of guide rail loading. For example, guide rails for a lift with a rated capacity of 1000 kg must be designed to resist a force of 0.65 kN perpendicular to the plane of the wall, and the supporting structure must deflect less than 3 mm. Allowable deflections are less for a high speed lift⁽⁶³⁾. Excessive deflections in service would compromise the functioning of the lift.

Tolerances on the plan dimensions of the lift shaft are given in BS 5655: Part 6. The tolerance on excess width and depth varies between 25 mm to 50 mm, depending on the height of the lift shaft. Tolerances for verticality of the shaft are the same as for the steel columns (see Section 8). For low rise buildings, connections at the guide rail interface generally provide sufficient adjustment to accommodate tolerances for verticality of the rails. Special tolerances for column verticality adjacent to the lift shaft may need to be specified by the structural designer for higher buildings.

ACTIONS - Lift installation

The design of interface elements will normally be undertaken by the lift manufacturer, but the structural designer should:

- allow for increased frame loads in the locality of the lift shaft if non-structural shaft walls are used
- simplify as far as possible the details of any secondary steelwork used for support
- be aware of the onerous tolerance requirements for the interface members, and design any secondary steelwork such that these can be satisfied
- communicate and cooperate with the lift manufacturer.

7.3 Metal cladding

Cladding is used to provide weather protection and insulation, and has a big influence on the appearance of the building. The choice of cladding should reflect not only the levels of erection and service loading, but also a need for sufficient robustness to avoid damage during transportation and site handling. Responsibility for the choice of cladding will vary according to the procurement process for a given project. However, all parties should be aware of the need for connection details which will accommodate the different tolerance requirements of the steel frame and the cladding.

Several different systems are available, some of which are shown in Figure 7.2. The characteristics of these options are described below. The choice of cladding

system depends on the required performance, appearance and cost. An important performance criterion which must not be forgotten is durability, which should be achieved through correct specification and detailing.

Single skin

Single skin cladding is the least expensive option. It may be suitable for buildings which do not require heating (agricultural sheds), or which are self heating (foundries). The designer should be aware that without insulation, condensation on the inside of the cladding (i.e. at the warm/cold interface) may lead to durability problems.

Insulated

Insulated cladding is the most common choice, because it is suitable for a wide range of buildings. The outer panels, insulating layer and inner steel liner panels are assembled on site.

Concealed fix

A concealed fixing system may be used to avoid perforations of the outer panel of insulated cladding (thus reducing the potential for leaks), and improve appearance. A typical concealed fix detail is shown in Figure 7.3a.

Standing seam

A standing seam system also avoids perforations of the outer panel, and permits significant 'longitudinal' movement. The latter characteristic means that longer panels can be used, since greater thermal expansion can be accommodated (see Figure 7.3b). Because the connections allow 'longitudinal' movement, the cladding may not provide full lateral restraint to the purlins.

Composite

Composite cladding is delivered to site as one unit, comprising two skins of steel with a foamed core. The skins and core act together structurally. Concealed fix or standing seam systems may be used for fixing.

Liner tray systems

Liner trays can be used to eliminate most sheeting rails and some purlins. The outer sheets are fixed either directly or through an insulating strip.

Flat panels

Flat panels with tongue and groove joints must be erected within very onerous tolerances, so that the joints can be made, and the finished surface is sufficiently 'planar' to meet architectural requirements. A means of adjustment between the primary steel frame and the panel support structure is therefore particularly important, so that any allowed deviation of the frame can be accommodated.

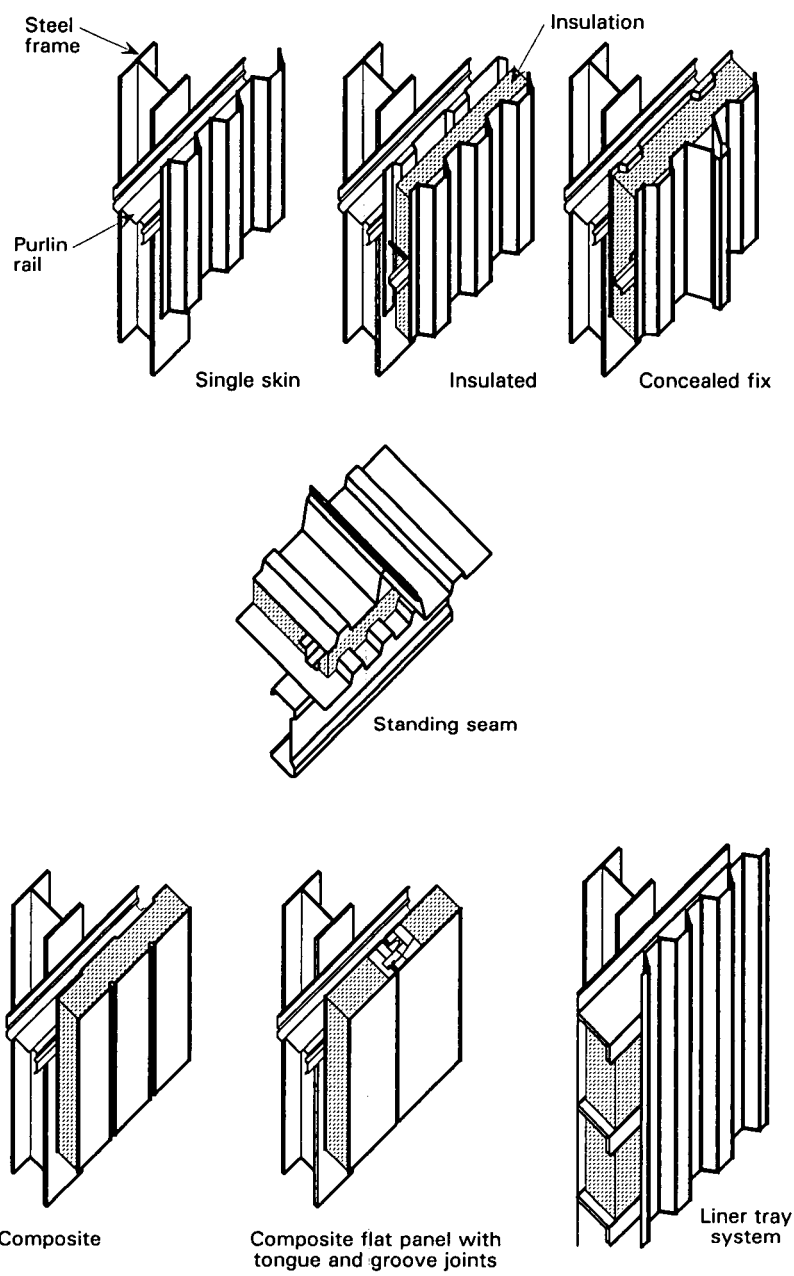

Figure 7.2 Metal cladding options

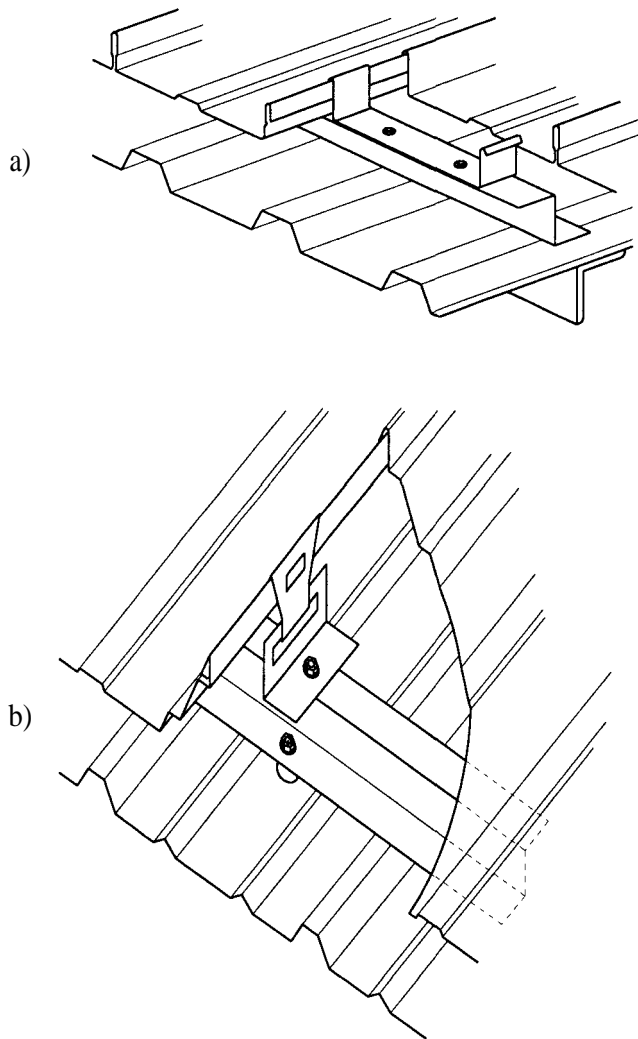

Figure 7.3 a) *Concealed fix* and b) *standing seam systems* (insulation omitted for clarity).

ACTIONS - Metal cladding

To facilitate construction, the following points should be considered during design:

- fixings should allow a means of adjustment between the steel frame and the cladding panels, so that different tolerance requirements can be accommodated
- cladding panels should be sufficiently robust to withstand transportation and reasonable handling on site.

7.4 Curtain walling

Curtain walling is the general description used for the external walls of buildings when they are constructed using a prefabricated framework that supports infill panels of glass or other materials. The framework is supported by the primary steel structure.

The connections used to fix curtain walling to a building are a key part of the whole walling system; they ensure that the panels perform correctly, and may affect the critical path of the construction programme. Depending on the curtain walling system and the procurement process, the connections may be designed by either the structural designer or the curtain walling specialist.

Connection details are similar for all types of panel; metal, concrete, glass or brickwork. One of their main tasks is to ensure that the curtain wall can be fixed in a position which satisfies specified tolerances, despite any allowed deviation of the primary steel frame. Curtain wall tolerances are more onerous than those for the steel frame. Typical tolerances on line, level, plumb and plane for a curtain wall are ± 2 mm over one storey height or structural panel width, and ± 5 mm overall.

Connection to the building frame may be constrained by the perimeter steelwork, the slab edge details and any services near the building perimeter. Connection positions should be defined early so that other parties involved in the building design have all the necessary information, and clashes are avoided.

The use of standard connection details and panel sizes facilitates work on site. To achieve standardisation, the number of different edge conditions should be minimised. For example, the structural designer could choose to specify the same size edge beams throughout the height of a building, when design requirements would allow the use of smaller beams in some locations. The extra frame costs will be compensated by savings in the cladding costs, or a shortening of the construction programme.

Curtain wall connections should be positioned to allow easy access for installation and inspection, and for the application of corrosion and fire protection. Top-of-slab connections are accessible, as are connections to the sides of columns. Several details are given and evaluated in *Curtain wall connections to steel flames*⁽⁶⁴⁾. Unless constrained by panel size or architectural requirements, connections should be made at or near column positions. When this is not possible, the edge beams may need to be designed to avoid excessive sag under vertical loads, and to resist torsional loading. This may result in heavier sections, or extra steelwork being needed.

Connections should be designed so that they can be pre-set to ensure panels are correctly aligned when attached. Doing so removes adjustment of the connections from the critical path. It also avoids double handling of the panels if they can be lifted straight from the delivery lorry into position. This reduces crane time, and eliminates the need for storage space. Because of these savings, the greater expense of the pre-set connections themselves may be more than justified. 'Fine tuning' of panel line and level, without the need of a crane, should be possible once the panel has been positioned. This will further reduce crane time requirements, and benefit the erection programme.

ACTIONS - Curtain walling

Responsibility for designing different aspects of the curtain walling will vary depending on the specified system and procurement process. The following list of actions may not therefore necessarily relate to the structural designer:

- communicate and cooperate with other designers, so that connection positions are identified early in the design process
- specify connections which allow sufficient adjustment to accommodate different tolerance requirements
- position connections so that they are accessible
- use connections which can be pre-set to ensure alignment before panels are lifted into place
- standardise and repeat details.

7.5 Glazing

There is an increasing use of sophisticated structural glazing in modern buildings. This term is normally used to describe systems where the glass is hung directly from a building or structure, without secondary framing for the glazing panels. The absence of secondary framing means that systems achieve a high degree of transparency, free from the visual intrusions of conventional transoms or mullions. The supporting steel structures are often based upon cables or tubes, and can themselves be highly expressive architectural elements.

One of the major difficulties to overcome is the detailing between the glass panels and supporting elements. Responsibility for this will depend on the project, but in all cases both the structural designer and glazing specialist must be aware of the interface requirements. Connections must be able to accommodate thermal movements, and different tolerance requirements for the two components. Examples may be found in Reference 65.

The most common form of attachment used in structural glazing involves bolting panels to the building edge, or to a supporting structure, through holes drilled in the glass. Holes are normally at the corners and along the long edges of rectangular sheets. Two examples of recent projects are the Waterloo international rail terminal, and the Chur rail and bus terminal in Switzerland. These are illustrated in Figures 7.4 and 7.5.



Figure 7.4 *Waterloo International Terminal, London*



Figure 7.5 *Chur Station, Switzerland*

ACTIONS - Glazing

The designer should detail the connections between the frame and glazing so that they are able to:

- accommodate allowed deviation of the steelwork whilst accommodating onerous tolerances for the glazing
- accommodate differential (thermal) movements in service.

7.6 Brickwork restraints

For general information concerning the design of brickwork, reference should be made to specialist literature. Only interface elements between the brickwork and steel members are considered in this Section.

Several examples of the wide range of proprietary frame ties are shown in Figure 7.6. These may be either zinc coated, or made from stainless steel, to prevent corrosion. The form of some ties encourages the collection of mortar droppings which can, if excessive, form a moisture 'bridge' across the cavity.

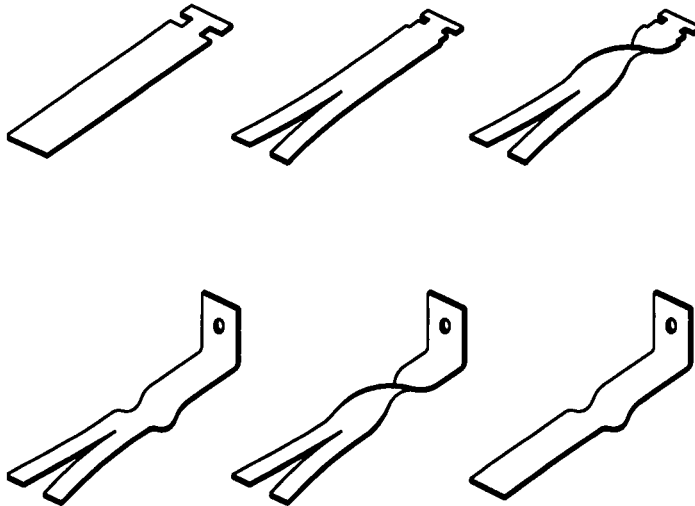

Figure 7.6 *Typical brickwork frame ties*

The designer should specify a method of fixing which allows vertical adjustment, to accommodate differences in level between the brickwork and steel. If bolts are used to fix the ties, vertical slotted holes should be drilled in the steel members during fabrication. Alternatively, self-drilling/tapping screws can be used for steel up to 20 mm thick, with ties up to 3 mm thick. Shot-fired connectors allow rapid fixing, but require skilled operatives and supervisors to ensure sufficient penetration of the nail to provide correct anchorage of the tie. A versatile method of attachment is to fix slotted tracks to the steelwork, either in the shop or on site, so that ties can be moved up and down the tracks as required. Care must be taken during transportation and on site, to ensure that the tracks are not damaged. When vertically flexible ties are used, they should not be bent excessively upwards. This

is to prevent water which penetrates the outer leaf coming into contact with the steel frame.

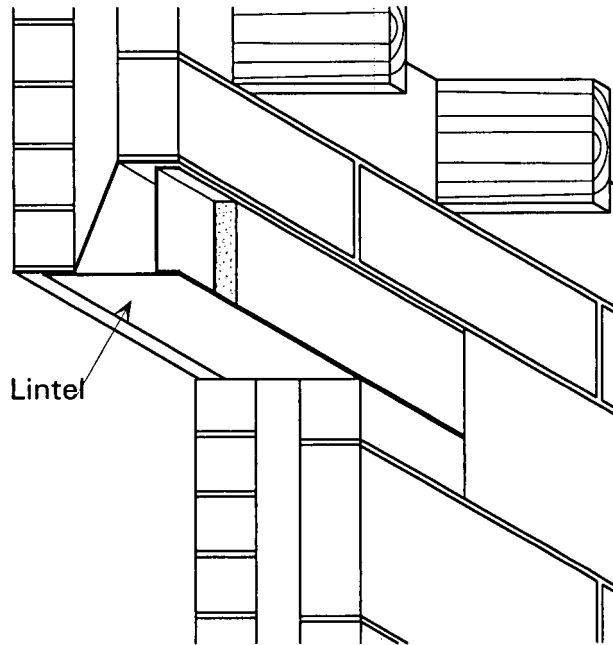

Figure 7.7 *Example of a steel lintel above a window*

Steel lintels may be used to support brickwork or masonry above windows and doors. Figure 7.7 shows an example of this type of application. Similarly, angles may be used to support brickwork cladding, as shown in Figure 7.8. Stainless steel is often used for this type of application ^(73,74). It can be seen from this figure that, as with brickwork ties, the designer must consider a means of accommodating differences in level between the steel and brickwork.

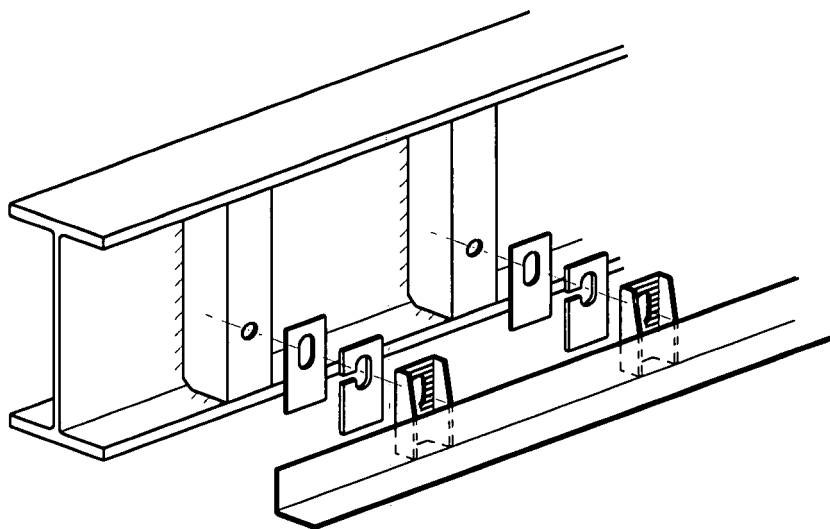

Figure 7.8 *Angle support for brickwork cladding*

ACTIONS - Brickwork restraints

The designer should specify ties:

- with provision for vertical adjustment, to accommodate differences in level between the steel frame and brickwork
- which are easy to place and adjust.

7.7 Surface protection

Surface protection of steel falls into two categories; corrosion protection (paint, galvanising etc.), and fire protection. As well as being used for protection, paint may be applied for decorative reasons. To avoid problems, the specifier must ensure that surface protection systems are compatible with one another.

7.7.1 Corrosion protection

Several types of paint and methods of application are suitable for shop use. Details of these are given in the *Design for manufacture guidelines*⁽¹⁾. Contact surfaces for non-slip connections, or any surfaces to be welded on site, must be clearly identified by the designer so that they remain unpainted by the fabricator.

Site painting is used for touching-up areas damaged during transportation or erection, or to cover site welds or other such details. Whilst the designer may have little influence over the extent of damage, he can reduce the number of site welds etc. requiring painting. Site painting is time consuming and therefore expensive, and can look unsightly.

Paint should be protected during transportation and erection to minimise damage. The specification of hard, two-pack chemical resistant paint reduces the likely extent of damage, but it is initially more expensive, more difficult to touch-up, and takes longer to cure. When additional coats of paint are required for decorative purposes they will generally need to be applied on site, and for convenience damaged paint can be touched-up as part of this operation. Controlling temperature and humidity, and keeping surfaces clean between the application of coats, may prove difficult on site unless the building envelope is sealed before touching up, or the application of additional coats, commences. Site welds should be minimised because they require careful cleaning and degreasing before paint is applied.

The designer should carefully consider the erection sequence and detailing of the frame, in order to minimise problems of access and painting at height. One option is to use sub-frames assembled at ground level.

KEY POINTS - Corrosion protection

The designer should ensure that:

- the corrosion protection system is compatible with other paint and fire protection systems to be used, since any incompatibility may only become apparent on site
- the design is such that the need to apply corrosion protection at height is minimised
- the protection specified is as resistant to damage during transportation and erection as possible.

7.7.2 Fire protection systems

Regulations dictate that most classes of building require fire resistance. An unprotected steel member could reach temperatures of more than 900°C in a fire. However, steel will begin to lose strength (and stiffness) at around 200°C, and its strength is halved at approximately 600°C. In buildings where fire resistance is required, steelwork is normally fire protected to enable the members to be designed using room temperature properties of the steel. However, steel members do not always have to be protected to achieve fire resistance. Some members, such as slim floor beam⁽⁵⁰⁾, can achieve 60 minutes fire resistance without applied protection. The fire resistant design of steelwork is covered by Part 8 of BS 5950⁽⁸⁵⁾, which contains approaches to reduce, or sometimes eliminate, fire protection of the steelwork.

Building regulations specify the degree of fire resistance in units of time (30 mins, 60 mins, 90 mins etc.). The required fire resistance depends mainly on the building height and usage, and whether sprinklers are installed. The most common requirement is for 60 minutes fire resistance. It is worth noting that the fire resistance periods do *not* represent the time during which the structure must remain standing so that occupants can escape. Fire resistance is a measure of performance determined using a standard fire resistance test, and is used by regulators to judge perceived risk and consequences for the occupants, contents and building itself.

Several types of surface treatment may be used to provide fire protection. Spray is the least expensive way to protect the steelwork, costing £ 8 to £12 per square metre applied (1996 prices), depending on thickness. Spray is generally in the form of cementitious or vermiculite material, is quick to apply, and can be used to cover complex details. Disadvantages of using a spray are that the application may sometimes be messy, difficult in winter, and may interfere with other trades. Some spray may also be aesthetically unacceptable for visible parts of the frame (see Figure 7.9). All areas of the steelwork must be suitably covered. For example, if spray is used on members above a suspended ceiling, the programming of work may well require that the protection is removed locally to allow subsequent fixing of ceiling hangers to the frame. Such areas need to be touched-up before completion.



Figure 7.9 *Sprayed fire protection*



Figure 7.10 *Board protection (Vicuclad, courtesy of Promat Ltd)*

An alternative to sprayed protection is boards, which are glued, screwed or otherwise attached to the steel members to provide insulation. They have the advantage that fixing interferes less with other trades on site. Boards are visually superior to sprays, and are therefore often used on visible members such as columns or exposed beams (see Figure 7.10). The principal disadvantage of boards is that for a comparable degree of protection, they are typically twice as expensive as sprayed material per unit area. It must be remembered, however, that the required area is less with boards, since they box-in a member, rather than being applied to all surfaces.

A third alternative for surface fire protection is the use of a thin intumescent coating. These may be up to 5mm thick, but thickness is typically only 1 to 2 mm. Although normally applied on site, these can now also be applied off-site by some fabricators. Such coatings have the same appearance as paint, and may be overcoated in a range of colours.

The use of off-site applied intumescent coatings is comparatively new. When this option is adopted care must be taken during transport and handling so that the coating is not damaged. This may involve the use of nylon slings instead of chains for lifting. A code requirement is that any damage is made good on site. A new industry standard has recently been published covering the off-site application of intumescent coatings⁽⁷⁸⁾. The cost of off-site application is higher than the more traditional onsite application, but savings in time on site will often outweigh the higher costs.

Other ways of providing fire resistance

Traditionally, concrete encasement has been used to provide fire protection. This is often uneconomical unless the concrete serves an additional role, for example as a load carrying component, or to prevent impact damage to a column. Beams with concrete in-fill between the flanges are heavier and therefore more difficult to erect than plain steel beams. They also require placement of in-situ concrete at connection points.

The designer may be able to eliminate the need for fire protection altogether, by a careful choice of section, thus saving time and money, and possibly improving aesthetics. Alternatively, he may be able to reduce the thickness of protection needed. Fire resistance decreases as the section factor of a member increases. This factor is the exposed cross-section perimeter length divided by the cross-sectional area. Figure 7.11 indicates maximum allowable section factors to provide 30 minutes resistance for a variety of sections.⁽³¹⁾ Composite slabs with mesh reinforcement provide 90 minutes fire resistance, and concrete filled hollow section columns provide 60 minutes resistance or more depending on the reinforcement. The designer should also consider positioning steel members in walls, for example, to eliminate or reduce the requirement for supplementary fire protection.

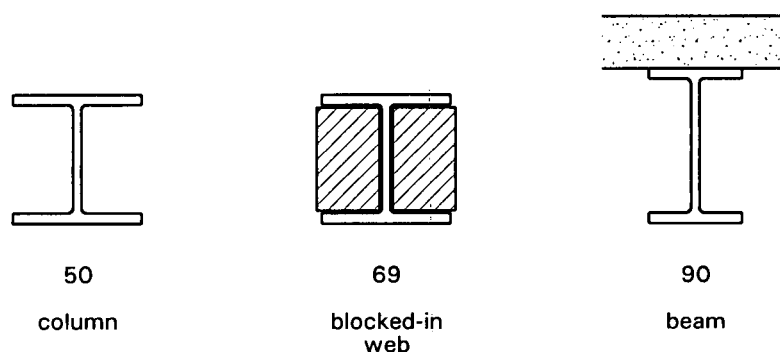

Figure 7.11 *Section factors to ensure 30 minutes resistance*

Many clients require active fire protection systems, such as sprinklers, to be installed for insurance reasons. As well as protecting the building, such ‘active’ systems reduce risks to occupants and contents. In these cases, the ‘fire engineering’ approach can be used to justify eliminating passive fire protection from many members.

KEY POINTS - Fire protection

The designer may choose any of the following options to provide the required fire resistance:

- spray: inexpensive, but messy and may interfere with other trades on site
- boards: look better than spray, more expensive
- intumescent coating: looks like paint, may prolong fabrication period, easily damaged, applied on or off-site
- concrete encasement: may serve another (e.g. structural) purpose
- increased section factor: reduce or eliminate the need for passive protection, thereby reducing site work
- sprinklers: eliminate passive protection, reduce risks to occupants and contents.

ACTIONS - Surface protection

The designer should ensure that:

- careful consideration is given to the different options available, since site requirements vary considerably
- specified layers of surface protection are mutually compatible
- protection is only specified when it's needed, so that unnecessary work is not carried out on site.

7.8 Further reading

(For further information, see Section 9, References)

Services

Services integration in modern steelframed buildings⁽⁶²⁾. Part of the SCI interfaces series. This publication reviews the general requirements for building services, considers how different long span composite floor systems accommodate services, and compares the costs of different options.

Space allowances for building services distribution systems - detail design stage⁽⁶⁶⁾. Gives sizes of standard ducts and fittings to enable the proper allocation and planning of service areas.

International convention centre, Birmingham - building services engineering ⁽⁶⁷⁾ . The first part of this paper presents a case study of the ventilation system for the Symphony Hall. The second part of the paper considers the electrical installation.

Lift installation

Electric lift installation in steelframe buildings⁽⁶³⁾ . Provides an overview of standard electric lift installations of the type normally used in steel framed buildings. Appraises and recommends various methods of attaching guide rails, landing doors, etc. to the building.

Metal cladding

The colorcoat building: design, specification and construction ⁽⁶⁸⁾ . Coverage includes achieving quality and performance, durability, appearance, definitions and system descriptions, structural requirements and building physics, cladding details, site practice, inspection and maintenance.

Design guides ⁽⁶⁹⁾ Six booklets published by the Metal Cladding and Roofing Manufacturers Association between 1991 and 1993, covering roofs, walls, fire guidance notes and more. Also includes a list of members of the MCRMA.

Durability of cladding - a state of the art report ⁽⁷⁰⁾ . Focuses on durability of coated metal cladding on industrial buildings, but also covers aspects of manufacture, design and detailing of cladding, life span, repair methods and problems in use.

Curtain walling

Interfaces: curtain wall connections to steelframes ⁽⁶⁴⁾ . This book is intended to promote efficiency in the design and erection of curtain wall systems, and their attachment to the steel frame.

Glazing

Interfaces: glazing ⁽⁶⁵⁾ . A guide dealing with connections between steel and glazing will appear as part of this series. Publication is planned for 1997.

New Steel Construction. This journal (for which an index is available ⁽⁷¹⁾) regularly features case study buildings which are of relevance. For example:

Swiss interchange ⁽⁷²⁾ . A two page article which contains an overview of the project at Chur Station.

Brickwork restraints

Brick cladding to steel framed buildings ⁽⁷³⁾ . The guide comprises two parts, *commentary* and *design examples*. It provides guidance to architects, engineers and technicians, with illustrations of modern practice combining a steel frame and brick cladding in a non-domestic building.

Design of stainless steel fixings and ancillary components ⁽⁷⁴⁾ . Presents guidance for the safe and efficient use of stainless steel fixings and ancillary components in general building construction. Covers mechanical and structural properties, durability, fabrication, site practice etc., including design examples.

Stainless steel angles for masonry support ⁽⁷⁵⁾ . Proposes a design method for stainless steel cold formed angles, as used to support the outer leaf of masonry cladding in buildings. Includes information on good construction practice.

Surface protection

Design for manufacture guidelines⁽¹⁾ Section 8 gives 14 pages of guidance concerning corrosion protection, including types of coating, environment, specification, surface preparation, application and galvanising. See also Further Reading in Section 2.4 of this document.

The steel designers' manual⁽³¹⁾ See also Further Reading in Section 3.9. Chapter 34 gives 13 pages covering fire protection and fire engineering. Subjects include standards and building regulations, structural performance in fire, methods of protection, fire testing, fire engineering. Chapter 35 gives 25 pages of coverage dealing with corrosion resistance. Subjects include the corrosion process, effect of the environment, surface preparation, metallic coatings, paint coatings, application of paints, weathering steels and the protective treatment specification.

Fire protection for structural steel in buildings. (Revised 2nd edition)⁽⁷⁶⁾. Provides comprehensive and up-to-date information on a wide range of proprietary fire protection materials and products. Includes data sheets and design tables.

The fire resistance of composite floors with steel decking (2nd edition)⁽⁴⁹⁾. Describes two methods of verifying the fire resistance of composite steel deck floors. Examples are given of both methods.

Fire resistant design of steel structures - a handbook to BS 5950: Part 8⁽⁷⁷⁾. Describes the background to the code and its use in practice.

Fire and steel construction: the behaviour of steel portal frames in boundary conditions⁽⁷⁸⁾ Outlines the background to the subject and describes the behaviour of portal frames in fire.

Structural fire design: of-site applied thinfilm intumescent coatings. Part 1: design guidance⁽⁷⁹⁾ gives the background to the use of off-site application of intumescent coatings. *Part 2: model specification* has been produced to try and achieve a greater uniformity in contract specifications.

Contact The Steel Construction Institute for details of other SCI publications dealing with the subject of fire.

8 TOLERANCES

Before discussing the subject of tolerances, it is wise, in the light of common misuse of relevant terminology, to clarify the meaning of terms which will be used in this Section.

- *deviation* misalignment (used here in the context of the frame),
- *lack of fit* local misalignment (used here in the context of frame components),
- *tolerance* limiting value for a deviation.

The relationship between these terms can best be illustrated using an example. Consider a 3 m high column forming part of a frame. When the frame is aligned and bolted up, the top of the column is offset 4 mm relative to a vertical line drawn from its base. This 4 mm is a frame deviation. The tolerance for non-verticality, expressed as an offset, is 5 mm according to the NSSS⁽⁶⁾. The column is acceptable because the tolerance of 5 mm exceeds the deviation of 4 mm. However, the non-verticality of the column may cause lack of fit between the components in the beam to column connections.

The word tolerance should not be used, as is often the case, to describe provision for adjustment to overcome lack of fit.

8.1 Reasons for tolerances

Structural and architectural tolerances on frame and member geometry are specified in order to ensure that the 'as built' frame geometry complies with the designer's assumptions. Failure to satisfy these tolerances may result in:

- premature failure of the frame due to secondary forces
- premature failure of individual components
- inability to fit other building components around the frame
- inability to meet architectural requirements.

These reasons should not be forgotten by any of the parties involved with the design or construction of a building. They are not arbitrary, and onerous tolerances should only be specified where necessary, for example at an interface.

The aim of the structural tolerances specified in BS 5950: Part 2⁽⁸⁵⁾ is to ensure that 'as built' imperfections are no greater than those assumed in the structural design calculations. Compliance guarantees that frame deviations will not cause secondary forces greater than those allowed for in the design. It also guarantees that lack of fit between the frame members will not be excessive. Limited lack of fit can be accommodated using appropriate packing, without adversely affecting the performance of the connections. Compliance with BS 5950: Part 2 does *not* ensure that the frame components will fit together within an envelope which is suitable for the other building components. A lack of appreciation that BS 5950: Part 2 only covers 'structural issues' is the most common source of problems at handover.

The NSSS specifies tolerances needed to satisfy wider conditions than BS 5950: Part 2. Quality and buildability of the structure, and requirements for the

components to fit together within the specified envelope are addressed. Requirements for specialist following trades such as glazing are not included.

The NSSS tolerances reflect the process capabilities of good modern practice, so that specified tolerances are achievable. To quote from the foreword to the Third Edition, *The object of the NSSS is to achieve greater uniformity in contract specifications issued with tender and contract documents. This Specification should be invoked as part of the individual Project Specification and thus be part of the total building contract.* The NSSS adds to and draws out some of the information which is contained in BS 5950, and which the client has in the past placed in a job specific technical specification. The NSSS can be used for all types of orthodox steel buildings designed for static loading.

The European Prestandard ENV1090-1⁽⁸⁸⁾, available in 1997, will eventually supersede BS 5950: Part 2. In it, consideration has been given to why tolerances are needed. For example, during code development, evidence from multi-storey buildings in Sweden and Canada indicated that between one third and one half of all the steel columns failed to meet the requirements for plumb then incorporated in an early draft. These requirements were substantially based on the NSSS. Closer investigation showed that the failure of individual columns to comply was not important, provided that groups of columns could be considered to be tied together for stability purposes. The ENV was modified to allow relaxation of the requirement for an individual column, provided it was tied to a further five columns, and that the group as a whole complied. The consequences of having an individual column outside the tolerance limits was deemed not to compromise the structure.

Whereas structural tolerances are generally given to ensure that the centerline of a member is in an acceptable position, architectural tolerances may be associated with the face of an element, or indeed may apply to surface finishes.

KEY POINTS - Reasons for tolerances

Reasons for specifying tolerances must be understood by those involved in both design and construction. They are specified in order to;

- avoid premature frame failure
- avoid premature component failure
- avoid clashes
- meet architectural requirements.

8.2 Inspection and test plan

The project *inspection and test plan* should lay down procedures for ensuring and demonstrating that the 'as built' frame satisfies specified tolerances. When the plan is implemented, the designer can be assured that his assumptions with regard to deviations are valid. Full details of items to be addressed in this plan are given in Table G.1 of ENV 1090 Part 1. Tests required at the handover stage are specified in terms of:

- the method of testing
- location and frequency of tests
- acceptance criteria
- actions to be taken if compliance is not achieved.

A dimensional survey is the usual method of testing, but its accuracy is limited by the accuracy of the surveying equipment. Dimensions are only measured to at best 2 mm, and often 5 mm, using optical instruments. This limited accuracy means that it may not be possible to achieve, or demonstrate, compliance of the frame.

A sequential, non-iterative process of plumbing-up is normally followed to bring the position of components within tolerance. This is not a final acceptance test as such. A simultaneous survey by engineers representing both the steelwork contractor and the main contractor is the most trouble-free way to achieve final acceptance. The process relies on an understanding of what is possible, and why tolerances are specified. Tolerance limits need not always be taken as go/no-go acceptance limits; the consequences of exceeding a limit should be considered before judging acceptability (see previous comments referring to how ENV1090-1⁽⁸⁸⁾ treats a group of columns).

Demonstration of compliance using a full three-dimensional survey of the complete structure as a final acceptance test is not practical, because of difficulty, time and expense. Neither is it necessary if the purpose is to ensure the stability of the frame. When tolerances are satisfied over a representative part of the frame, deviations in the rest of the frame can be assumed to be acceptable based on a visual inspection alone. Often the frame may be represented by no more than one quarter of the frame nodes. As well as considering representative parts of the frame, testing should also cover those parts where deviations are critical. Ideally, plumbing-up should begin with braced regions, and end where onerous tolerances are specified at interfaces with, for example;

- cladding
- lift shafts
- crane rails
- architectural features.

Tolerances specified in the NSSS for erected steelwork assume that the frame position is checked under the self weight of the steel members alone.⁽¹⁰⁾ Due consideration must also be given to the fact that the frame position will vary according to wind loading, so checks should be made in calm weather conditions. The influence of differential temperatures must also be considered; the NSSS specifies a reference temperature of 20°C.

8.3 Further reading

(For further information, see Section 9, References)

Tolerances in steel construction⁽⁸⁰⁾. A three page article which gives good background to what tolerances are, why they are required and what different specifications contain.

The National Structural Steelwork Specification for Building Construction, 3rd Edition ⁽⁶⁾. Presents tolerances for fabrication and erection operations. See also *Further Reading* in Section 2.4.

A suggested design procedure for accuracy in building ⁽⁸¹⁾. Suggests a systematic design procedure. Covers design and site aspects.

9 REFERENCES

1. CIMSTEEL
Design for manufacture guidelines
The Steel Construction Institute, 1995
2. The Construction (Design and Management) Regulations, 1994
HMSO, 1995
3. CONSTRUCTION INDUSTRY RESEARCH AND INFORMATION
ASSOCIATION
Special Report No. 26 - Buildability: An assessment
CIRIA, 1983
4. Communication of structural design
Institution of Structural Engineers, 1975
5. CIMSTEEL
Modelling of steel structures for computer analysis
The Steel Construction Institute, 1995
6. THE BRITISH CONSTRUCTIONAL STEELWORK ASSOCIATION, and
THE STEEL CONSTRUCTION INSTITUTE
The National Structural Steelwork Specification for Building Construction,
3rd Edition
BCSA and SCI, 1994
7. ROYAL INSTITUTE OF BRITISH ARCHITECTS
Plan of Work
RIBA, 1997
8. GRAY, C., HUGHES, W. & BENNETT, J.
The successful management of design - a handbook of building design
management.
Centre for Strategic Studies in Construction
University of Reading, 1994
9. Aims of structural design, 2nd Edition
The Institution of Structural Engineers, 1969
10. STAINSBY, R.
Commentary on the third edition of the National Structural Steelwork
Specification for Building Construction
BCSA and SCI, 1996

11. CONSTRUCTION INDUSTRY RESEARCH AND INFORMATION ASSOCIATION
Special Publication 84
Quality management in construction - contractual aspects
CIRIA, 1992
12. LAWSON, R.M.
Comparative structure cost of modern commercial buildings
SCI, 1993
13. GIRARDIER, E.V.
Customer led - Construction led (Series of 4 articles)
BCSA Steel Construction, February 1991, August 1991, February 1992
New Steel Construction, February 1993
Chapter 1 - The right attitude to erection
Efficient erection
The construction led steelwork contractor
Chapter 2 - A series of bullet action points arising from a BCSA seminar entitled 'Best practice in steel erection'
Chapter 3 - Fully threaded bolts
Chapter 4 - The role of standardised connections
14. THE STEEL CONSTRUCTION INSTITUTE, and THE BRITISH CONSTRUCTIONAL STEELWORK ASSOCIATION
Joints in simple construction - Volume 1: Design methods (2nd edition)
SCI and BCSA, 1993
15. THE BRITISH CONSTRUCTIONAL STEELWORK ASSOCIATION, and THE STEEL CONSTRUCTION INSTITUTE
Joints in simple construction - Volume 2: Practical Applications
BCSA and SCI, 1992
16. THE STEEL CONSTRUCTION INSTITUTE, and THE BRITISH CONSTRUCTIONAL STEELWORK ASSOCIATION
Joints in steel construction - Moment connections
BCSA and SCI, 1995
17. ANDERSON, E., READING, S.J. & KAVIANPOUR, K.
Wind moment design for unbraced frames
SCI, 1991
18. THE STEEL CONSTRUCTION INSTITUTE
Semi-continuous braced frames
SCI, 1997
19. COMITE INTERNATIONAL POUR LE DEVELOPPEMENT ET L'ETUDE DE LA CONSTRUCTION TUBULAIRE
Design guide for circular hollow section joints
CIDECT, 1991
20. OWENS, G.W.
The use of fully threaded bolts for connections in structural steelwork for buildings
The Structural Engineer, September 1992

21. DOWLING, P. J., HARDING, J. E. & BJORHOVDE, R
 Constructional steel design - An interim guide
 Elsevier Science, 1992
22. BOSE, B. & HUGHES, A. F.
 Verifying the performance of standard ductile connections for semi-
 continuous steel frames
 Proceedings of the Institution of Civil Engineers, Structures and Buildings,
 November 1995
23. BROWN, D. G., FEWSTER, S. M. C., HUGHES, A. F. & OWENS, G.
 W.
 A new industry standard for moment connections in steelwork
 The Structural Engineer, October 1996
24. CONSTRUCTION INDUSTRY RESEARCH AND INFORMATION
 ASSOCIATION
 Technical Note 98
 Design guidance notes for friction grip bolted connections
 CIRIA 1980
25. THE STEEL CONSTRUCTION INSTITUTE
 Steelwork design guide to BS 5950, Volume 4 - Essential data for designers
 SCI, 1991
26. FISHER, J. M. & WEST, M. A.
 Serviceability design considerations for low-rise buildings
 AISC, 1990
27. GRAY, C. & LITTLE, J.
 A systematic approach to the selection of an appropriate crane for a
 construction site
 Centre for Strategic Studies in Construction, University of Reading
28. GRAY, C.
 A case study of the steel frame erection at Senator House, London
 SCI, 1993
29. ARCH, W.H.
 Structural steelwork - erection
 BCSA, 1988
30. LOVEJOY, E.G., STAMPER, H.R. & ALLEN, P.H.
 Erector's manual
 BCSA, 1993
31. Steel designers manual, (5th edition)
 SCI and Blackwell Science Publishers, 1992
32. TAGGART, R.
 Steelwork erection (Guidance for designers)
 British Steel SPCS, 1991

33. CONSTRUCTION INDUSTRY RESEARCH AND INFORMATION ASSOCIATION
Special publication SP131
Crane stability on site
CIRIA,1996
34. SPACKMAN, R.A.
Selection of cranes
Steel Construction Today, Vol. 5, No. 3, May 1991
35. Where hire, 1996 - The contractors guide to plant and tool hire companies throughout the UK
Emap Construct
36. THE STEEL CONSTRUCTION INSTITUTE
New steel workway - the way ahead for the UK steel construction industry
SCI, 1989
37. BUILDING RESEARCH ESTABLISHMENT
Report 173: Design guide for wind loads on unclad framed building structures during construction
BRE, 1990
38. CONSTRUCTION INDUSTRY RESEARCH AND INFORMATION ASSOCIATION
Report 87
Lack of fit in steel structures
CIRIA, 1981
39. CONSTRUCTION INDUSTRY RESEARCH AND INFORMATION ASSOCIATION
Report 68
Lateral movement of heavy loads
CIRIA,1977
40. HEALTH AND SAFETY COMMISSION
Managing construction for health and safety - Construction (Design and Management) Regulations, 1994. Approved code of practice.
Health and Safety Executive, 1995
41. BROWN, D.G.
The Construction (Design and Management) Regulations, 1994
Advice for designers in steel
SCI, 1997
42. HEALTH AND SAFETY EXECUTIVE
Guidance Note GS 28: Safe erection of structures
HMSO, 1984
43. CONSTRUCTION INDUSTRY COUNCIL
Opportunities and Impositions
CIC, 1995

44. JOYCE, R.
The CDM regulations explained
Thomas Telford Publications, 1995
45. CONSTRUCTION INDUSTRY RESEARCH AND INFORMATION
ASSOCIATION
Report 145
CDM Regulations - Case study guidance for designers: an interim report
CIRIA, 1995
46. CONSTRUCTION INDUSTRY TRAINING BOARD
Construction site safety - Safety notes
CITB, 1996
47. CONSTRUCTION INDUSTRY ADVISORY COMMITTEE
Designing for health and safety in construction
HSE, 1995
48. OGDEN, R.G. & HENLEY, R.
Interfaces: Connections between steel and other materials
SCI, 1996
49. NEWMAN, G.M.
The fire resistance of composite floors with steel decking (2nd edition)
SCI, 1991
50. MULLETT, D.L.
Slim floor design and construction
SCI, 1992
51. NETHERCOT, D. A. & LAWSON, R. M.
Lateral stability of steel beams and columns
SCI, 1992
52. BRITISH STEEL
The section book
British Steel Corporation, BCSA, 1982
53. RHODES, J. & LAWSON, R.M.
Design of structures using cold formed steel sections
SCI, 1992
54. Holding down systems for steel stanchions
Constrado, BCSA, The Concrete Society, 1980
55. Steel Construction Yearbook 1997
McMillan - Scott PLC, 1997
56. HAYWARD, A., WEARE, F.
Steel detailers' manual
Blackwell Science Publishers, 1980

57. LAWSON, R.M.
Design of composite slabs and beams with steel decking
SCI, 1989
58. LAWSON, R. M.
Commentary on BS 5950: Part 3: Section 3.1 Composite beams
SCI, 1990
59. LAWSON, R.M., MULLET, D.L., & WARD, F.P.D.
Good practice in composite floor construction
SCI, 1990
60. CHUNG, K.F.
Building design using cold formed steel sections: worked examples to
BS 5950: Part 5: 1987
SCI, 1993
61. TREBILCOCK, P. J.
Building design using cold formed steel sections: An architects' guide
SCI, 1994
62. McKENNA & LAWSON, R.M.
Services integration in modern steel framed buildings
SCI, 1997
63. OGDEN, R.G.
Electric lift installation in steel frame buildings
SCI and the National Association of Lift Manufacturers, 1994
64. OGDEN, R.G.
Curtain wall connections to steel frames
SCI, 1992
65. STEEL CONSTRUCTION INSTITUTE
Glazing interfaces (provisional title)
SCI, to be published
66. BUILDING SERVICES RESEARCH AND INFORMATION
ASSOCIATION
Technical note 10/92
Space allowances for building services distribution systems - detail design
stage
BSRIA, 1992
67. DIX, T.R. & JONES, K.M.
International Convention Centre, Birmingham - Building services
engineering
Proceedings of the Institution of Civil Engineers, Structures and Buildings,
August 1992
68. BRITISH STEEL
The Colorcoat building - Design, specification and construction
British Steel, 1996

69. METAL CLADDING AND ROOFING MANUFACTURERS' ASSOCIATION
Design guides
MCRMA, 1991-1993
70. RYAN, P. A., WOLSTENHOLME, R. P., and HOWELL, D. M.
Durability of cladding - A state of the art report
Thomas Telford, 1994
71. THE STEEL CONSTRUCTION INSTITUTE
New Steel Construction magazine index 1992-97
SCI, 1997
72. HUGHES, A.F.
Swiss interchange
New Steel Construction, Volume 2, No. 3, 1994
73. BRITISH STEEL, BRICK DEVELOPMENT ASSOCIATION
Brick cladding to steel framed buildings
BDA and BSC, 1986
74. BADDOO, N.R.,
Design of stainless steel fixings and ancillary components
SCI, 1993
75. STEEL CONSTRUCTION INSTITUTE
Stainless steel angles for masonry support
SCI, 1995
76. ASSOCIATION OF SPECIALIST FIRE PROTECTION CONTRACTORS AND MANUFACTURERS LIMITED, THE STEEL CONSTRUCTION INSTITUTE, and FIRE TEST STUDY GROUP
Fire protection for structural steel in buildings (revised 2nd edition)
ASFPCM/SCI/FTSG, 1992
77. LAWSON, R.M. & NEWMAN, G.M.
Fire resistant design of steel structures - a Handbook to BS 5950: Part 8
SCI, 1990
78. NEWMAN, G.M.
Fire and Steel Construction: the behaviour of steel portal frames in boundary conditions
SCI, 1990
79. YANDZIO, E., DOWLING, J. J. & NEWMAN, G.M.
Structural fire design: off-site applied thin film intumescent coatings
SCI, 1996
80. POPE, R.
Tolerances in steel construction
New Steel Construction, Vol. 3, No. 2, April 1995

81. CONSTRUCTION INDUSTRY RESEARCH AND INFORMATION
ASSOCIATION
Technical note 113
A suggested design procedure for accuracy in building
CIRIA, 1983

82 - 88, see Section 10

10 CODES AND STANDARDS

A list of most relevant codes and standards are given in this Section. Numbered references correspond to those cited in the text. *BS* documents are listed first, in numerical order, followed by other appropriate standards.

82. **BS 466: 1984**
Specification for power-driven overhead travelling cranes, semi-goliath and goliath cranes for general use

83. **BS 2573:**
Rules for the design of cranes
Part 1: 1983 Specification for classification, stress calculations and design criteria for structures
Part 2: 1980 Specification for classification, stress calculations and design mechanisms

BS 5400:
Steel, concrete and composite bridges
Part 1: 1988 General statement
Part 2: 1978 Specification for loads
Part 3: 1982 Code of practice for design of steel bridges
Part 5: 1979 Code of practice for design of composite bridges
Part 6: 1980 Specification for materials and workmanship, steel

BS 5531: 1988
Code of practice for safety in erecting structural frames

BS 5606: 1990
Guide to accuracy in building

84. **BS 5655:**
Lifts and service lifts
Part 5: 1989 Specification for dimensions of standard lift arrangements

85. **BS 5950:**
Structural use of steelwork in building
Part 1: 1990 Code of practice for design in simple and continuous construction: hot rolled sections
Part 2: 1992 Specification for materials, fabrication and erection: hot rolled sections
Part 3: Design in composite construction
Part 3: Section 3.1: 1990 Code of practice for design of simple and continuous composite beams
Part 4: 1994 Code of practice for design of composite slabs with profiled steel sheeting
Part 5: 1987 Code of practice for design of cold formed sections
Part 6: 1995 Code of practice for design of light gauge profiled steel sheeting
Part 7: 1992 Specification for materials and workmanship: cold formed sections
Part 8: 1990 Code of practice for fire resistant design

Part 9: 1994 Code of practice for stressed skin design

86. **BS5964:**

Building setting out and measurement

Part 1: 1990 Methods of measuring, planning and organisation and acceptance criteria

Part 2: 1996 Measuring stations and targets

Part 3: 1996 Checklists for the procurement of surveys and measurement services

BS 5973: 1993

Code of practice for access and working scaffolds and special scaffold structures in steel

BS 5974: 1990

Code of practice for temporarily installed suspended scaffolds and access equipment

BS 5975: 1996

Code of practice for falsework

BS 6954:

Tolerances for building

Part 1: 1988 Recommendations for basic principles for evaluation and specification

Part 2: 1988 (1994) Recommendations for statistical basis for predicting fit between components having a normal distribution of size

Part 3: 1988 (1994) Recommendations for selecting target size and predicting fit

BS 7121:

Code of practice for safe use of cranes

Part 1: 1989 General

BS 7307:

Building tolerances. Measurement of buildings and building products

Part 1: 1990 Methods and instruments

Part 2: 1990 Position of measuring points

BS 7308: 1990

Method for presentation of dimensional accuracy data in building constructions

BS 7334:

Measuring instruments for building construction

Part 1: 1990 Methods for determining accuracy in use: theory

BS 8000:

Workmanship on building sites

Part 1 - Part 15

BS 8004: 1986

Code of practice for foundations

BS 8093: 1991

Code of practice for the use of safety nets, containment nets and sheets on constructional works

87. **BS 8110: Structural use of concrete**

Part 1: 1985 Code of practice for design and construction

CP3010: 1972

Code of practice for safe use of cranes (mobile cranes, tower cranes and derrick cranes)

(Partially replaced by Parts 1 and 2 of BS 7121)

88. **DD ENV 1090**

Execution of steel structures

ENV 1090-1: 1996 General rules and rules for buildings

DD ENV 1993: Eurocode 3. Design of steel structures

DD ENV 1993-1-1: 1992 General rules and rules for buildings (together with United Kingdom National Application Document)

ENV 1993-1-2: 1995 General rules - structural fire design

ENV 1993-1-3: 1996 General rules - supplementary rules for cold formed thin gauge members and sheeting

ENV 1993-1-4: 1996 General rules - supplementary rules for stainless steels

DD ENV 1994: Eurocode 4: Design of composite steel and concrete structures

DD ENV 1994-1-1: 1994 General rules and rules for buildings (together with United Kingdom National Application Document)

ENV 1994-1-2: 1994 General rules - structural fire design

BS EN ISO 9001: 1994 Quality systems. Model for quality assurance in design, development, production, installation and servicing

APPENDIX A - Additional information

A.1 Introduction

Most buildings are one-off designs, which means that structural designers cannot use exact repeats of previous practice when designing a new building. Nevertheless, the designer will generally benefit from drawing on past experience. The purpose of this Appendix is to collate useful information relating to existing designs for steel framed buildings.

Section A.1 provides general guidance on typical tonnages (per unit area and per unit volume) for steelwork used in various types of building. These values are intended to give the designer an indication of the frame weight to expect. It should be noted that the values given do not represent upper and lower bounds of acceptability; depending on the design criteria a well designed frame might quite reasonably have a weight falling outside the specified range. The values given are purely and simply intended for guidance.

Section A.2 lists references to specific case studies that illustrate particular solutions that may be useful in developing the conceptual design - particularly with clients and architects unfamiliar with steel framed building design.

Section A.3 provides warnings about past experiences that turned sour. It draws on a wide range of investigations of defects and failures to provide a checklist of possible problems to watch out for.

A.2 Typical tonnages for various types of building

Typical tonnages for various types of building are given in Table A.1.

Table A.1 *Steel framed buildings - typical weights*

Type of building	Typical range of weight per unit volume kg/m ³	Typical range of weight per unit area kg/m ²	
Sheds (or halls)			
Saw-tooth roof structures	4.6 to 7.2	30 to 47	
Single bay buildings with lattice girders	4.3 to 6.3	26 to 38	
Single bay buildings with roof trusses	4.2 to 6.0	25 to 36	
Single bay portal-framed buildings	without overhead cranes	4.8 to 7.2	31 to 47
	with overhead cranes	6.0 to 10.0	60 to 100
Multi-bay portal-framed buildings	without overhead cranes	4.3 to 6.8	28 to 44
	with overhead cranes	5.5 to 10.0	55 to 100
Special hall structures (e.g. space frames)	5.5 to 10.0	44 to 80	

Type of building		Typical range of weight per unit volume kg/m ³	Typical range of weight per unit area kg/m ²
Hangars and Grandstands			
Aeroplane hangars	without overhead cranes	4.7 to 8.5	47 to 85
	with overhead cranes	6.0 to 11.5	60 to 115
Grandstands		5.1 to 10.5	51 to 105
Multi-storey Buildings			
Low rise (2 to 6 storeys)		9.0 to 12.8	36 to 51
Medium rise (7 to 12 storeys)		11.5 to 17.5	46 to 70
Car parks		8.9 to 16.3	31 to 57
Industrial Plant Buildings			
Plant buildings	without steel flooring	7.8 to 10.9	70 to 98
	with flooring	9.3 to 12.4	84 to 112
Heavy plant buildings (e.g. BOS plants)		11.1 to 21.7	100 to 195

NOTES: Weights above include cold-formed and hot-rolled steelwork.

Weight comparisons per unit volume are more reliable indicators than weight per unit area, hence the weights per unit area are simply derived from those per unit volume using the typical heights.

Design studies can underestimate the weight of steel in the completed building by as much as 30%.

A.3 Case study references

It is not possible to reproduce in this document the depth of information that is required for a comprehensive number of case studies. This Section, therefore, identifies sources of case study material, with a brief description of the types of building considered. References are listed in Table A.2.

Table A.2 *Case study references*

Title		Reference
Offices - High Rise		
Flexibility on-site at Peterborough Court		Steel Construction Today, Vol. 4, No. 6
Beaufort House		Steel Construction Today, Vol. 4, No. 6
Grand buildings, Trafalgar Square, London, WC2	Using "Christmas tree" columns	Steel Construction Today, Vol. 4, No. 6
Lee House Development	Spanning a road	Steel Construction Today, Vol. 4, No. 6
Westminster & Chelsea Hospital		Steel Construction Today, Vol. 4, No. 6
Embankment Place	Suspended over a station	Steel Construction Today, Vol. 5, No. 5
Offices - Other		
British Gas Research Centre	Medium rise	New Steel Construction, Vol. 1, No. 2
Civil Aviation Authority Centre	Large span	New Steel Construction, Vol. 1, No. 6
The Cable & Wireless College, Coventry	Modern design & build development	New Steel Construction, Vol. 2, No. 3
Doctors' Surgery, Chipping Ongar	Glass facade, single storey on stilts	Framed in Steel, No. 2
Guardian Royal Exchange Complex	Range of buildings	Framed in Steel, No. 3
BMW Headquarters, Bracknell	Using the parallel beam approach	Framed in Steel, No. 5
Genesis Centre, Warrington	Low rise portal	Framed in Steel, No. 7
Cutlers Court, London	Medium rise	Framed in Steel, No. 10
Lloyds Chambers, London	Medium rise with atrium	Framed in Steel, No. 11
Bury Court House, London	High tech	Framed in Steel, No. 12
Embassy House, Birmingham	11 storey	Framed in Steel, No. 13
No. 1 Finsbury Avenue	Medium rise	Framed in Steel, No. 14
Cavern Walks, Liverpool	Retail & offices, atrium	Framed in Steel, No. 15
Billingsgate redevelopment	Medium rise	Framed in Steel, No. 16
London Bridge City	Medium rise with a galleria	Framed in Steel, No. 18

Title		Reference
Earls Court 2, London	Large span tubular arch truss roof	Framed in Steel, No. 19
Conoco Ltd, Warwick	Medium rise parallel beam approach	Framed in Steel, No. 22
Quarry House, Leeds	Medium rise	Framed in Steel, No. 23
HM Customs & Excise HQ, Liverpool	Medium rise	Framed in Steel, No. 24
Sheriff Court, Edinburgh	Medium rise with complications	Framed in Steel, No. 25
Brown Thomas Department Store, Dublin	Medium rise with retained facades	Framed in Steel, No. 26
Ionica, St John's Innovation Park, Cambridge	Medium rise high-tech	Framed in Steel, No. 27
Guildhall Yard East (Transfer Deck), London	Suspended plaza over ancient monument, plus a new building with offices, museum, etc.	Framed in Steel, No. 28
Centre 1 Inland Revenue, East Kilbride	Medium rise	Framed in Steel, No. 29
Stansted Airport, New Terminal Building	198 m x 162 m roof using large CHS	Case Studies, No. 3
Sterling Hotel, Heathrow Airport	Atrium	Case Studies, No. 4
Stadia (and other Large Span)		
Steel in the Waterloo International Terminal	Tubular truss roof	Steel Construction Today, Vol. 4, No. 6
The Metro Space Frame Roof to Birmingham's National Indoor Arena for Sport	Large span space frame roof	Steel Construction Today, Vol. 5, No. 2
Main Stand redevelopment at Ibrox Stadium	Large span tubular lattice structure and large span portal frames	Steel Construction Today, Vol. 5, No. 4
Sheffield International Arena	Double layer grid space frame using DCs	Steel Construction Today, Vol. 5, No. 4
The Construction of New Exhibition Halls for Wembley Stadium Ltd	Several large span roofs	Steel Construction Today, Vol. 5, No. 4
Sports Facilities in London's Docklands	Large span bolted trusses and lattice columns	Steel Construction Today, Vol. 5, No. 4
Steelwork Aspects of the new North Stand at Twickenham for the Rugby Football Union	Tubular cantilever trusses	Steel Construction Today, Vol. 5, No. 4

Title		Reference
The Dutch Pavilion	Tubular steel hall	Steel Construction Today, Vol. 6, No. 3
The Finnish Pavilion	Tubular steel hall	Steel Construction Today, Vol. 6, No. 3
Old Trafford gets new stand	Large grandstand	New Steel Construction, Vol. 4, No. 2
Wimbledon No. 1 Court: new roof	Circular stadium roof	New Steel Construction, Vol. 4, No. 2
Ibrox Stadium	New grandstands for the existing stadium	Framed in Steel, No. 6
Spectrum Arena	Trussed roof sports hall	Framed in Steel, No. 8
The Dome, Doncaster Leisure Park	190 m x 100 m roof in CHS	Case Studies, No. 2
Ponds Forge International Sports Centre, Sheffield	Curved roof spans using cast nodes	Case Studies, No. 5
Clydebank Tourist Village	Roof support by ties	Case Studies, No. 7
Manchester Airport	Space frames and tapered tubular trusses	Case Studies, No. 8
Retail		
Clayton Square Shopping Centre	Shopping mall	Steel Construction Today, Vol. 2, No. 1
Savacentre, Oldbury		Framed in Steel, No. 9
Metrocentre	Shopping mall	Framed in Steel, No. 17
The Square, Towncentre, Tallacht	Shopping mall with pyramid roof	Framed in Steel, No. 20
St Enoch Centre, Glasgow	Roof over shopping mall in CHS	Case Studies, No. 1
Industrial		
Express extension: recent developments at Express Newspaper's Manchester printing works	Contains plant supporting structures	Steel Construction Today, Vol. 3, No. 1
Tyseley Power Station	Tall plant-supporting structure	New Steel Construction, Vol. 3, No. 5
Herman Miller Factory, Bath	Large span single storey factory	Framed in Steel, No. 1
Refurbishment		
Liverpool Street Station - West train shed roof	Modern match to a Victorian structure	Steel Construction Today, Vol. 5, No. 5
82 Lombard Street, London	Refurbishment of historic building	Framed in Steel, No. 4

Title		Reference
33 Grosvenor Place, London	Medium rise refurb of shell	Framed in Steel, No. 21
Hangars		
Raising the Roof - FFV Aerotech's Manchester Hangar		Steel Construction Today, Vol. 5, No. 2
Project Dragonfly	Large span tubular trusses	New Steel Construction, Vol. 1, No. 5
British Airways Heavy Maintenance Hangar, Cardiff	232.5 m total roof span over 3 bays	Case Studies, No. 6
Car Parks		
Farnham Road Car Park, Guildford		Steel Construction Today, Vol. 5, No. 5

- * Steel Construction Today was published by the SCI.
New Steel Construction is published by the SCI/BCSA.
Framed in Steel is published by British Steel.
Case Studies are published by British Steel Tubes & Pipes.

A.4 Potential defects

Table A.3 contains a list of common potential defects. In interpreting the list, it is important to bear in mind that perfection is not an attainable goal. Some degree of imperfection or permissible deviation must always be tolerated, and suitable allowances made in the design. Small deviations do not generate defects.

Although defects do not always lead to failure, they do so sometimes with catastrophic consequences. The designer's aim must be to enable fail-safe construction, or construction that is robust against relatively minor defects.

A latent defect can become evident either by directly causing failure, with local or perhaps global collapse ensuing without warning, or by initially causing distress without structural failure. Clearly the latter type of behaviour is to be preferred, and in most cases the inherent ductility of steel is of great value. Care is needed to avoid brittle fracture, which is non-ductile, or buckling, where ductility is of little benefit.

Table A3 *List of potential defects*

Context	Potential problems that could lead to defects or failure
Design	
Checking of calculations for gross errors	Gross errors, including those due to 'blind' use of software, are most likely to occur during structural analysis. Misconceptions about the behaviour of the structure can occur, which may cause long term problems if they are not picked up before or during erection. Mistaken sizing may also occur, but this is more likely to be detected during the detailing process, provided experienced personnel are used.
Reliance on computer-based design	
Accidental load cases	The likely sources of overload need to be identified. In industrial structures, it is common for large moving objects, such as lorries, to damage or remove columns if such key elements are unshielded.
Stability against collapse	A frequent cause of flawed conceptual design is lack of provision for stability against collapse. Suitably strong and stiff system bracing or sway frames have to be provided in both lateral directions, and restraint against torsional collapse can be essential in asymmetric buildings. Distribution of these actions to the foundations must follow suitable load paths, with attention given to how load shedding would occur from one path to another under accidental load cases - to prevent disproportional collapse. For example, there is a code requirement for groups of multi-storey columns to be tied together.
Slender members	Local failure is often caused by instability of slender members, for example beams or trusses which fail due to lateral or lateral torsional buckling. A common cause is the omission or deterioration of the required restraint bracing.
Susceptibility to minor errors in execution	Whilst steel is generally a robust and ductile material able to accommodate 'errors', some members and configurations are susceptible to relatively minor errors of execution or damage. The thinner or more slender the member, the more likely this is to occur. For example, special care may be needed with large diameter thin-walled tubes, cold formed sections, and tie bars or cables.
Foundation movement	To the steelwork designer who is used to precision, soil mechanics can seem like a black art. Foundation movement, laterally or through settlement or heave, can severely strain the steel structure. Usually, however, noticeable distress gives warning of impending failure, and time for corrective action to be taken.
Extensions	It is dangerous to assume that an existing structure can be extended without reconsideration of the original design. For instance, the extension could increase the loads being picked up by wind bracing in the original structure. Fixing to an existing member can change its behaviour by, for example, introducing additional restraint. Furthermore, loads from the existing structure can be diverted inadvertently into the extension.

Context	Potential problems that could lead to defects or failure
Dynamic loads	Fatigue failures are amongst the most common causes of failure in steel structures. Fatigue due to prolonged vibrations is rare, but fatigue caused by dynamic loads induced by mechanical equipment is much more common. Sometimes these are ignored by the designer, or equipment is installed later without reconsideration of the structural implications. Occasionally the frequency of equipment usage increases significantly beyond the design condition allowed for, reducing the fatigue life critically. Special care may be needed where fretting occurs, or corrosive conditions exist alongside cyclic actions.
Code usage	Design codes are carefully "drafted attempts" to provide a safe procedure for design. They are usually conservative. By their nature, the procedures are selective, and not all conceivable cases are covered. 'Blind' application of the code rules, without an understanding of the underlying principles, can lead to inappropriate use. Loading values given in codes are given as guides, albeit authoritative and conservative ones. Exceptional, unexpected loading can sometimes occur, for instance in store rooms, safes or battery rooms.
Specification	
Steel grades and subgrades	Extensive European standards (BS ENs) for steel products exist, and they define a wide range of materials. Some are unsuited to welding, possessing carbon equivalent values that are too high; some are unsuited to use externally, possessing Charpy impact values that are too low. Wrongly specified material can cause failure in, for example, thick tension members without adequate notch ductility.
Special steels	The range of steel materials used in mechanical engineering is much wider than the range of weldable structural steels. Some of the former may be used for structural components, for example machined pins or high strength ties. Particular care is needed however in their specification, as welding may be difficult if not impossible, and inappropriate welding may initiate defects.
Fastener selection	As with steels, the range of structural fasteners is wide, and the range of mechanical fasteners used structurally much wider. Care in specification and observance of manufacturer's instructions is essential. This is particularly important because many fasteners achieve high strengths at the expense of poor ductility, which can be critical in prying, or where stress concentrations occur (for example when too few threads share the strain).
Fastener treatment	Some fasteners, for instance those made from higher grade steels, are susceptible to hydrogen embrittlement. Pickling during galvanising, and other acid based treatment processes, introduces hydrogen into the steel surface. This hydrogen must be driven off by stoving if failure is to be avoided.

Context	Potential problems that could lead to defects or failure
Detailing	
Match to principal structural design	Design decisions made during detailing must be compatible with the main design concept and analysis. The incidence of mismatches, some potentially serious, has resulted in the development of a clear brief for the exchange of information between principal structural design and detailer. This information is listed in Appendix A of BS 5950: Part 2, and in more detail in the NSSS. An example of a potentially serious defect arising from such a mismatch would be the unrestricted use of hard stamping, introducing hard spots or cracks in critical zones such as plastic hinges.
Codes for detail design	Not all authoritative design practice is codified in British Standards. Industry standards can also provide essential guidance. The extensive range of books on tubular structures published by CIDECT are an example. Designers who do not seek or heed the advice given in such publications are more likely to produce defective designs.
Connection positions and types	Connections, including splices, are not always located at member ends. The choice of location and the type of detail may affect the way in which loads are distributed by the structure. Splices in compression members must be designed for initial imperfections that may exceed those assumed for the unspliced member, otherwise premature buckling may occur.
Corrosion	Sealed hollow sections do not corrode internally as there is no supply of oxygen or water to sustain the process. However, incomplete seal welds, porosity of seal welds, or penetrations of tube walls by fasteners can introduce holes through which moisture and air can pass. Poor details for open sections, when used externally or in humid environments, can also introduce water traps.
Bimetallic interfaces	Accelerated corrosion may occur at bimetallic interfaces. Lack of consideration of this effect at interfaces with stainless steel or aluminium can result, for example, in early failure of sheeting fasteners.
Following trades	Holes and attachments to suit the following trades are frequently added to the steel members at the detailing stage. Occasionally, these can have a critical influence on the performance of the steel member. An example would be the removal of a substantial portion of the web of a beam for service penetration.
Execution	
Quality control	Quality cannot be inspected into a product, it needs to be rooted in proper quality control practices that check the proper functioning of the processes involved, and include provision for action to be taken before the product in general reaches the minimum specified level. Without this, any sample testing of end products for acceptance will be at best haphazard, resulting in no confidence that the remaining unsampled selection does not contain a significant number of non-conforming items.

Context	Potential problems that could lead to defects or failure
Steel	<p>The use of poor or substitute materials, for example thick plates with laminations or cracks, or cold formed tubes instead of tubes specified as hot finished, can result in critical latent defects. Occasionally, fabricators who are used to using material that exceeds the specified minimum by some margin are supplied with a barely-complying product. Unexpected problems can then occur, for example with welding.</p> <p>Traceability of material composition and properties back to the producer is important, and only certain inspection documents (previously termed test certificates) supplied by the producer provide sufficient details. Reliance on an established and competent producer can help to prevent such difficulties arising. However, a clear understanding of the product standards for the material involved is still important. For instance, BS EN 10025 includes specification options that are critical to weldability and ductility.</p>
Fit-up prior to welding	<p>The progenitor of a good weld is good fit-up between the parts before welding. An excessive root gap leads to secondary stresses due to eccentric load paths throughout the weld, and can cause lack of fusion, especially at unbacked joints.</p>
Distortion	<p>High heat inputs during welding can result in distortion of the weldment due to differential restraint conditions during thermal expansion and subsequent contraction. Heat treatment of the completed weldment will relax any residual stresses, but may not succeed in resetting the weldment back to its intended shape.</p>
Site welds	<p>Some welds are poorly executed because access to the weld is difficult. This is more common on site, where items are often fixed in orientation thus dictating, for example, the need for overhead welding. Another difficulty with site welding is that the joints can be fixed in position with a very high degree of restraint. As all welds shrink during cooling, pull-out of plugs of the parent material can occur (although this would rarely escape inspection).</p>
Erection method statement	<p>Without a clear and well thought-out method statement, serious problems can occur during erection. The most critical aspect is control of overall stability against collapse. In very rare cases, erection can be completed apparently satisfactorily, yet with serious incipient problems stemming from a 'meta-stable' structure. For instance, a large dead load could be balanced on a beam whose lack of robustness against lateral buckling could be precipitated later. Also, the installation of bracing is a critical activity. On tall buildings, bracing in the lower stories can be compressed as columns shorten, resulting in lateral bowing of the bracing. This can damage adjacent walls, as well as compromising the response behaviour of the structure to lateral loads.</p>
Symptoms of problems	<p>Experience during erection can often be used to prevent the incorporation of latent defects into the structure. For instance, columns which are difficult to plumb, column splices which do not seat properly, bracings which do not fit properly, or hips which require significant site remedial work may all be signs of deeper problems.</p>

Context	Potential problems that could lead to defects or failure
Selection of items for test	<p>Inspection and testing usually involves a sampling procedure, and hence relies for its efficacy on a predetermined pattern of sampling that concentrates on the most critical items. Some checks are of the functioning of the system, some are intermediate tests of work in progress, and some are final acceptance tests. A clear inspection and test plan specifies the method and accuracy required for the tests, the location and frequency of testing, the acceptance criteria, and actions to be taken when non-conformities occur - such as the procedure for dealing with requests for concessions. Without a clear plan, undetected defects are much more likely to have a significant effect.</p>
Maintenance	<p>Whilst lack of maintenance is not a cause of latent defects, regular maintenance may be valuable for their identification. Planned inspection and treatment is far less likely to be carried out where suitably easy access is not provided. Another essential is that suitable personnel undertake such inspections. For instance, the removal of relatively light restraint, or of system bracing members, might seem innocuous to the untrained eye, yet such members may be essential for stability against structural collapse.</p>
Change of use	<p>As with maintenance, change of use (together with refurbishment, renovation and adaption) can either help remove defects or introduce new ones. Incipient failure can be detected using the symptoms of distress. Alternatively, fatal flaws can be introduced, such as where the lattice bracing of a truss is removed to allow the passage of a new ventilation duct.</p>

